

# FLEXIJOINT®



**E**THYLENE

**Flexijoint: The Severe Service Standard**

# FLEXIJOINT®

## Flexijoint® Description

Ethylene Flexijoint PTFE expansion joints are flexible connectors and tremor barriers designed to compensate for misalignment, absorb expansion and contraction, and isolate vibration and shock in process piping, tanks and pumps. They also offer a low spring rate to protect stress sensitive FRP, glass or graphite equipment. Flexijoints are available in sizes 1/2" to 42" and from 2 to 12 convolutions for maximum movements. Flexijoint has almost universal chemical inertness, high and low temperature resistance, invulnerability to ozone and sunlight, outstanding flex life, and low acoustical impedance (sound dampening properties)

### Important Note

Good engineering practice says to use expansion joints as a last resort and try to eliminate them whenever possible; however, when your stress analysis indicates they are required, they should be viewed as a "critically important engineered piping component" and NOT just a piping commodity.

### Table Of Contents

Flexijoint Description .....	3
Distinctive Features .....	4-5
Flexijoint Styles .....	6-7
Options .....	8
Weak Link .....	9
Quick Selection Guide.....	10-11
1/2" to 42" Selection Charts .....	12-59
Pressure / Temperature Charts	
Weights	
Axial, Angular, Lateral Movements	
Spring Rates	
Vacuum Ratings	
Flange Dimensional Data .....	60
Technical Data.....	61
Typical Installations .....	62
Common Applications .....	63
Flexijoint vs. Competition .....	63-65
Application Data Sheet .....	66
How To Order .....	67
How To Specify.....	67
Ethylene Products .....	68



# FLEXIJOINT<sup>®</sup>

# Distinctive Features

## 1 Pure 100% Virgin PTFE Resin

The unmatched performance of Flexijoint is due to its exclusive Fluorforming™ process, a development of Ethylene. The Fluorforming process employs only high molecular weight resin to utilize pure PTFE with no pigments or additives which might contaminate contacting fluids by leaching out, or to be vulnerable to blistering. In addition, high molecular weight with tightly controlled crystallinity, inherent in the Ethylene Fluoriform process, results in lower permeation rates, outstanding flex-life and maximum tensile strength.

*Competitors which use paste extruded resin are NOT using Pure PTFE. They must mix a hydrocarbon such as Isopar to facilitate PTFE paste extruding.*

## 2 Uniform Wall Thickness

Ethylene's exclusive Fluorforming™ process guarantees multiple convolution walls of constant uniform thickness for any size. This relationship of heavy wall and geometry is one of the basic reasons for the outstanding performance of Flexijoints. Deep convolutions allow increased axial travel and also reduce the force necessary to produce movement or lateral misalignment. As a result, Flexijoints have a longer service life when compared to conventional blow molded or stretch molded expansion joints which introduce stress points and exhibit alarming thinning of the convolution wall and root.

*Note: Blow-molding is sometimes referred to as "contour" molding by some manufacturers.*

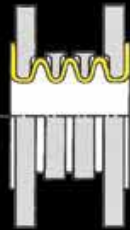

## 3 T-Band™ Root & Sidewall Support

Flexijoint T-Band reinforcement on the outside of the convolutions supports the convolution root and sidewall for improved service life and increased safety in high pressure applications. As pressure and temperature increase, the sidewall of the PTFE convolutions conform to the contour of the T-Band, improving stability under pressure.



## 4 T-Band™ Protection From Over Compression

Flexijoint T-Band metal reinforcement on the outside of the convolutions not only contributes to the pressure rating of the Flexijoint but also limits the total axial movement in compression. The shoulders of the T-Band are designed to butt when maximum compression limit has been reached to provide protection from excessive compression for improved safety and increased service life.

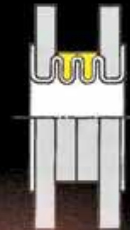

## 5 LimitLinks™ Protection From Over Expansion

LimitLinks consist of stainless steel cables conforming to MIL-C5424, Government specification for Aircraft Cable, at the ends of which are stainless steel ball-shaped terminals are swaged. The opposite ends of the each LimitLink are firmly anchored in the Flexijoint flanges in a manner which limits over expansion of the Flexijoint but also leaves the terminals free to swivel as the flanges change position relative to each other during their adjustment to angular misalignment, parallel misalignment, purely axial motion or a combination of all three.

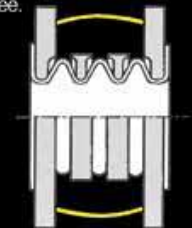

## 6 LimitLinks™ & T-Band™ Additional Benefits

LimitLinks provide easy installation even when the mating flange bolts don't align. They also won't get in the way and they never need to be removed for installation unlike competitors LimitBolt designed expansion joints which may void warranties. T-Bands cover approximately 75% of the outside of the convolution when not compressed to provide protection from external damage such as falling tools or weld splatter.

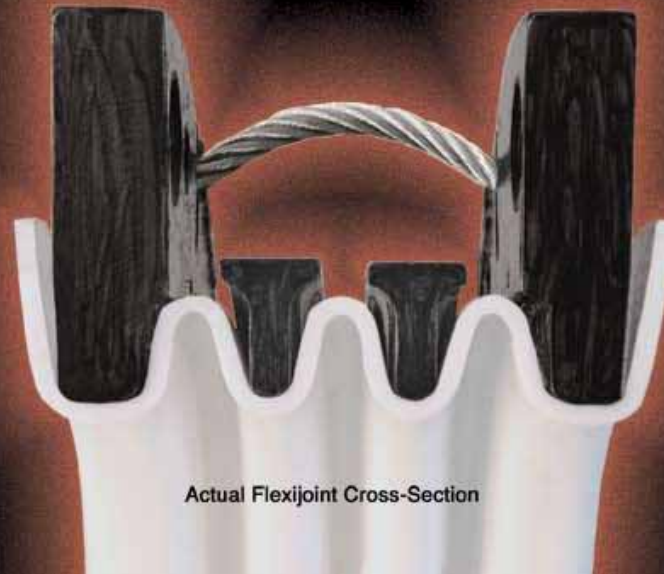
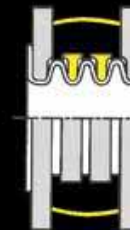

Actual Flexijoint Cross-Section

# FLEXIJOINT<sup>®</sup> Styles



## LimitBolt

Provides resistance to rotational forces and limits lateral misalignments. Unlike competitors, Flexijoint LimitBolt design does not require the removal of LimitBolts for installation.



## LimitLink™

The industry standard and regarded as the most reliable PTFE expansion joint for severe services. Flexijoint with LimitLinks allow free swivel as the flanges change position relative to each other during their adjustment to angular and parallel misalignment, purely axial motion or a combination of all three. LimitLink also permits installation where mating pipe is not two-holed.



## AntiSquirm™

Each T-Band™ incorporates (3) radial spokes which rest on the LimitBolts, thereby restraining the T-Bands that hold the convolutions in balanced geometrical position. This feature will eliminate squirming or buckling effects and dramatically increase operating pressure capabilities in multi-convoluted Flexijoints.



## Durcor-62™

Advanced composite flanges have the strength of steel with 1/2 the weight and will never corrode. **ZERO CORROSION RATE!** Request brochure "FlexDurcor" for more information.



## FlexArmor®™

PTFE lined metal expansion joints provide double containment protection and higher pressure ratings. Request brochure "FlexArmor" for more information.



## Hinged

Flexijoint Hinged style expansion joints contain pivots which only allow the unit to bend in a single plane. Their hinge mechanisms are very effective at absorbing pressure - thrust and other external loads, such as the weight of adjacent piping, relieving the piping designer of having to provide additional supports and anchors as required by standard type expansion joints.

The Flexijoint shown is provided with hinge pin holes which are slotted to permit limited axial travel. These slotted hinge types will not resist pressure - thrust loads, and anchoring must be provided.



## AnchorBase™

AnchorBase is basically an anchor built around a LimitBolt Flexijoint. It is ready for bolting to a footing, floor or other structural element of suitable mass. Distance from Flexijoint centerline to base bottom conforms to ANSI B16.5 for 150 lb base fittings.



## Universal

Flexijoint Universal expansion joints consist of two bellows separated by a PTFE lined pipe spool. The primary purpose of this arrangement is to have a unit which will accept large amounts of lateral deflection and substantially reduced force (spring rate) required to cause movement.



## Gimballed

Gimballed Flexijoint is basically the same as the hinge type except that instead of being limited to deflection in only a single plane, it can accept bending in any plane. It contains two sets of hinges connected to a central floating gimbal ring. Gimballed joints are the most reliable form of a flexible connector and are widely used for complex piping systems where proper anchoring & guiding may not be feasible. These flexible connectors, usually in pairs, will permit piping to float in relation to terminal points.



## Specials

Don't want flanges on your expansion joints? Ethylene can provide cuffed ends for clamping directly to piping or virtually any other end connection on Flexijoints, including Tri-Clamp & Victaulic. Contact Ethylene for details.



# FLEXIJOINT®

## Options

Don't let an economical expansion joint be the ~~weak~~ link in your piping system  
**Dangerous**

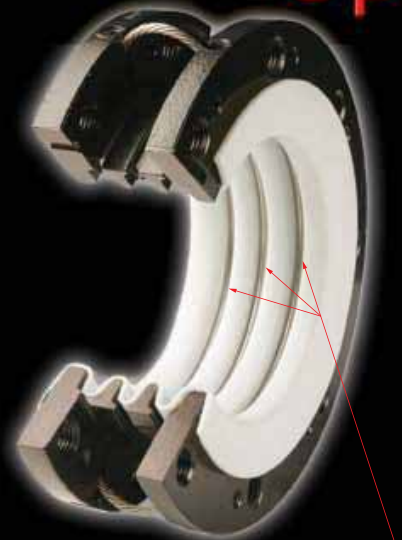

### VacuBands™

The vacuum rating of any PTFE expansion joint decreases with increasing temperature, diameter, and number of convolutions. VacuBands enable Flexijoints through 42" diameter to be rated for FULL VACUUM at +450°F. The VacuBand is an alloy hoop inserted into the I.D. root of the convolution. Alloy selections include Tantalum, Hastelloy, Monel, Zirconium, Nickel and Stainless Steel.

- Other Flexijoint Options include:**
- Grounding Straps
  - Spray Shields
  - Special Lengths
  - Carbon Steel Flanges
  - 316 Stainless Flanges
  - Durcor-62™ Advanced Composite Flanges
- Zero Corrosion Rate

**Warning:**  
 Safety shields must always be used in hazardous service to protect against serious personal injury in the unlikely event of a Flexijoint failure.

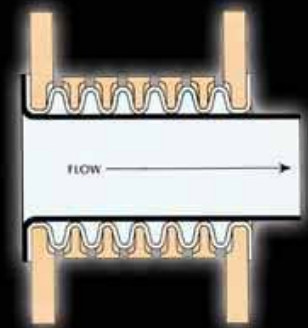

### LinerSleeves®

It is recommended that LinerSleeves be inserted through Flexijoints when any of the following conditions exist.

- 1) The fluid contains abrasive solids
- 2) The fluid holds material that may settle out in the convolutions
- 3) The fluid velocity is high
- 4) The fluid is steam

LinerSleeves may be ordered in PTFE or metal. They are flared on one end and clamped between the upstream Flexijoint flange and its mating flange in the piping system. Ability of the Flexijoint to adjust to misalignment is usually not seriously affected with a PTFE LinerSleeve. A metal one however, does offer some interference and is not generally recommended where severe angular or parallel misalignment may be present.

### Ethylene Safety Shield



## Flexijoint®: The Severe Service Standard



# FLEXI<sup>1/2"</sup>JOINT<sup>®</sup>



Number of Convolutions	Length (in.)	Axial Movement (+/- in.)	Lateral Movement (+/- in.)	Angular Movement (deg)	Axial Spring Rate (lb./1/8 in.)	Lateral Spring Rate (lb./1/8 in.)	Angular Torque (in.-lb./deg)	Std. Full Vacuum Temp (°F)	Vacubands™ Full Vacuum Temp (°F)	Weight (lbs)
2	1.61	0.31	0.24	19°	40.0	31.0	0.4	450	450	2.0
3	2.17	0.47	0.35	28°	15.0	25.0	0.3	450	450	2.1
4	2.68	0.63	0.47	37°	5.0	12.5	< 0.1	450	450	2.2
5	3.23	0.79	0.55	45°	2.0	12.5	< 0.1	425	450	2.3
6	3.78	0.94	0.67	53°	2.0	8.3	< 0.1	400	450	2.4
7	4.33	1.06	0.83	60°	1.5	3.1	< 0.1	400	450	2.5
8	4.84	1.22	0.94	67°	1.5	3.1	< 0.1	400	450	2.6
9	5.39	1.38	1.02	74°	1.0	3.1	< 0.1	400	450	2.7
10	5.94	1.54	1.14	79°	1.0	2.5	< 0.1	400	450	2.8
11	6.50	1.69	1.28	84°	0.8	2.2	< 0.1	400	450	2.9
12	7.06	1.84	1.41	89°	0.6	2.0	< 0.1	400	450	3.0

⚠ Data applicable to LimitLink design only - AntiSquirm design is intended for axial movements only

## LimitLink™ Flexijoint<sup>®</sup>

Working Pressure vs. Temperature (Non-Shock)

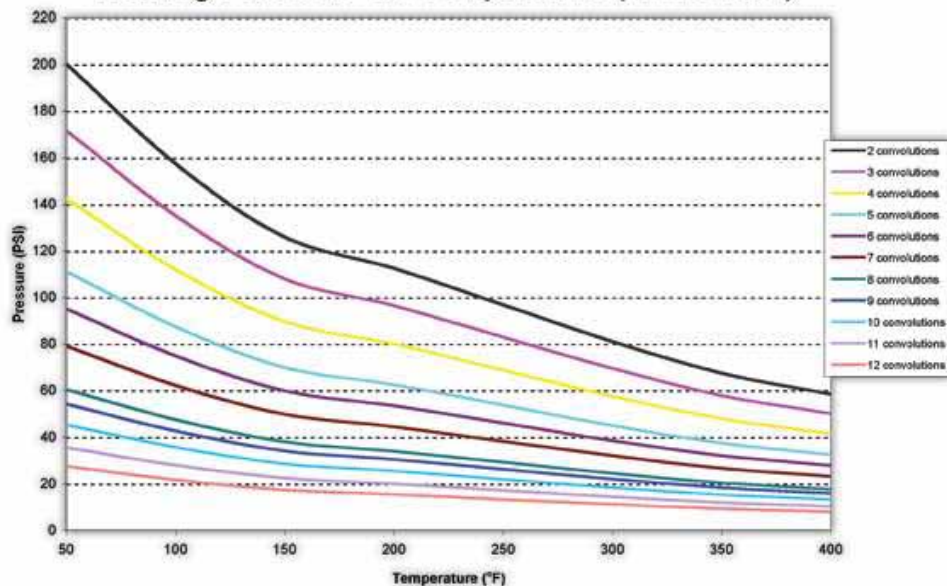

## AntiSquirm™ Flexijoint<sup>®</sup>

Working Pressure vs. Temperature (Non-Shock)

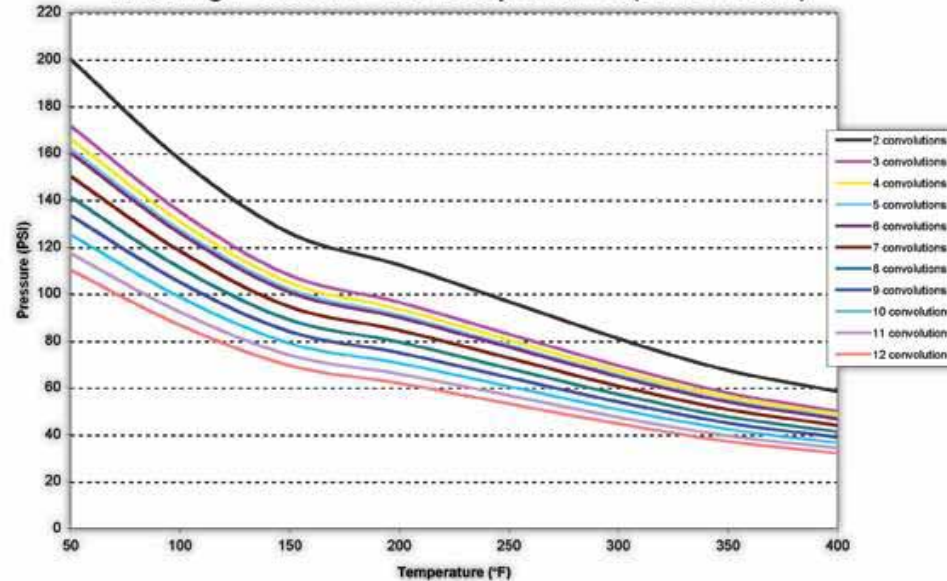

# FLEXIJOINT<sup>®</sup> 3/4"



Number of Convolutions	Length (in.)	Axial Movement (+/- in.)	Lateral Movement (+/- in.)	Angular Movement (deg)	Axial Spring Rate (lb./1/8 in.)	Lateral Spring Rate (lb./1/8 in.)	Angular Torque (in.-lb./deg)	Std. Full Vacuum Temp (°F)	Vacubands™ Full Vacuum Temp (°F)	Weight (lbs)
2	1.61	0.31	0.24	17	45.0	50.0	0.5	450	450	2.0
3	2.20	0.47	0.35	25	20.0	37.5	0.4	450	450	2.2
4	2.72	0.63	0.47	34	10.0	18.8	0.1	450	450	2.4
5	3.27	0.79	0.59	41	2.0	18.8	< 0.1	425	450	2.6
6	3.82	0.94	0.67	49	2.0	9.4	< 0.1	400	450	2.8
7	4.37	1.10	0.83	56	1.5	3.1	< 0.1	400	450	3.0
8	4.92	1.26	0.94	62	1.5	3.1	< 0.1	400	450	3.2
9	5.47	1.42	1.06	68	1.0	2.5	< 0.1	400	450	3.4
10	5.98	1.57	1.14	74	1.0	2.5	< 0.1	400	450	3.6
11	6.56	1.72	1.28	80	0.8	2.2	< 0.1	400	450	3.8
12	7.13	1.88	1.41	86	0.5	2.2	< 0.1	400	450	4.0

☀ Data applicable to LimitLink design only - AntiSquirm design is intended for axial movements only

## LimitLink™ Flexijoint<sup>®</sup>

Working Pressure vs. Temperature (Non-Shock)

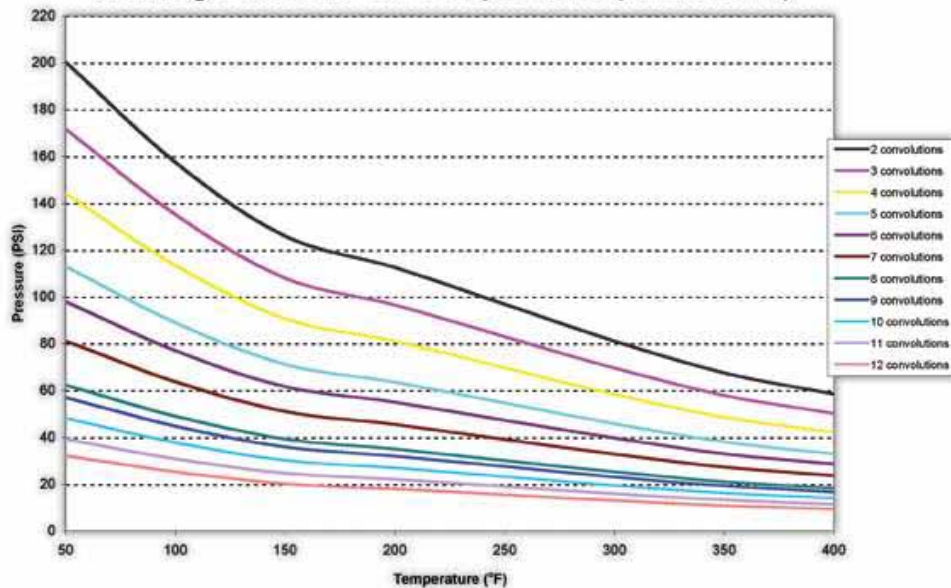

## AntiSquirm™ Flexijoint<sup>®</sup>

Working Pressure vs. Temperature (Non-Shock)

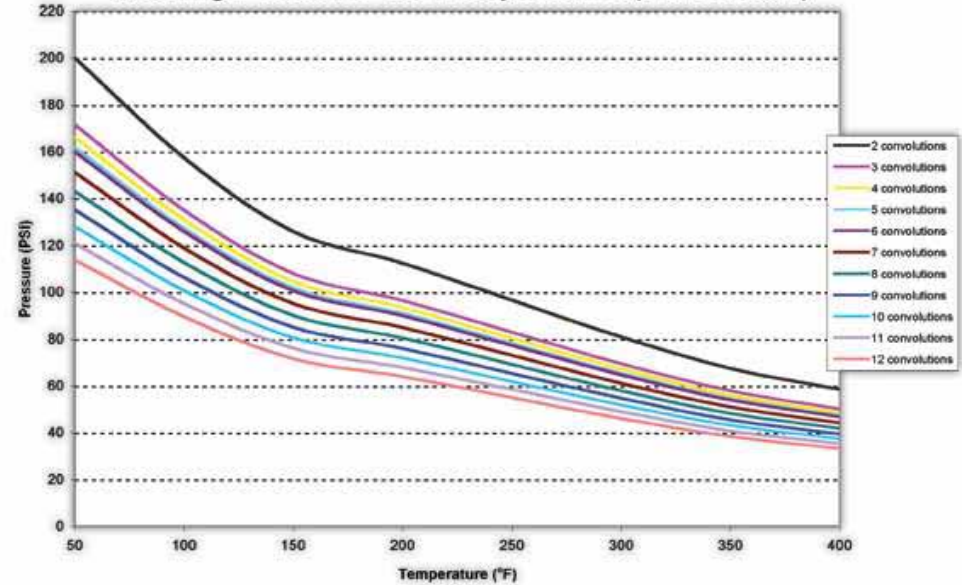



# FLEX1" JOINT®



Number of Convolutions	Length (in.)	Axial Movement (+/- in.)	Lateral Movement (+/- in.)	Angular Movement (deg)	Axial Spring Rate (lb./1/8 in.)	Lateral Spring Rate (lb./1/8 in.)	Angular Torque (in.-lb./deg)	Std. Full Vacuum Temp (°F)	Vacubands™ Full Vacuum Temp (°F)	Weight (lbs)
2	1.73	0.35	0.24	16	50.0	62.5	0.7	450	450	3.0
3	2.32	0.51	0.39	24	25.0	50.0	0.4	450	450	3.2
4	2.91	0.67	0.51	31	15.0	21.3	0.3	450	450	3.4
5	3.50	0.83	0.63	39	5.0	25.0	0.1	425	450	3.6
6	4.06	0.98	0.75	45	5.0	12.5	< 0.1	400	450	3.8
7	4.65	1.14	0.87	52	2.0	6.3	< 0.1	400	450	4.0
8	5.24	1.30	0.98	58	2.0	3.1	< 0.1	400	450	4.2
9	5.83	1.50	1.14	64	1.5	3.1	< 0.1	400	450	4.4
10	6.42	1.65	1.26	70	1.5	2.5	< 0.1	400	450	4.6
11	7.00	1.81	1.38	76	1.3	2.3	< 0.1	400	450	4.8
12	7.59	2.00	1.50	82	1.3	2.2	< 0.1	400	450	5.0

☀ Data applicable to LimitLink design only - AntiSquirm design is intended for axial movements only

## LimitLink™ Flexijoint®

Working Pressure vs. Temperature (Non-Shock)

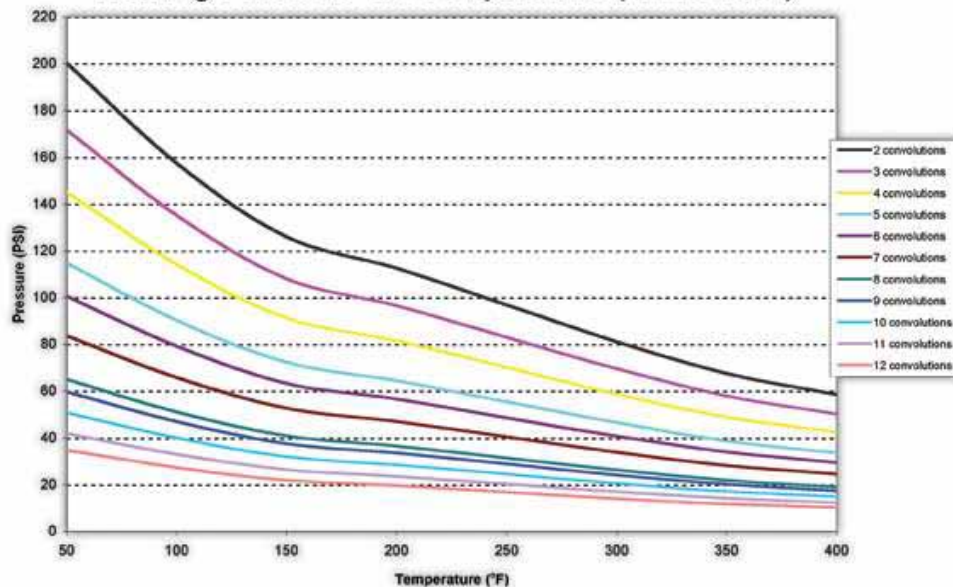

## AntiSquirm™ Flexijoint®

Working Pressure vs. Temperature (Non-Shock)

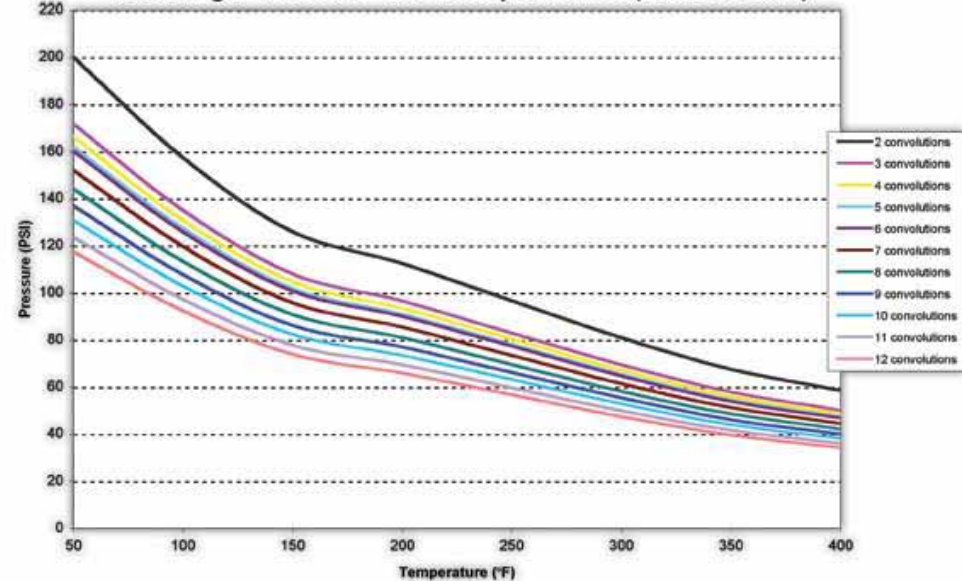

# FLEX1.25"INT®



Number of Convolutions	Length (in.)	Axial Movement (+/- in.)	Lateral Movement (+/- in.)	Angular Movement (deg)	Axial Spring Rate (lb./1/8 in.)	Lateral Spring Rate (lb./1/8 in.)	Angular Torque (in.-lb./deg)	Std. Full Vacuum Temp (°F)	Vacubands™ Full Vacuum Temp (°F)	Weight (lbs)
2	1.73	0.35	0.24	16	50.0	62.5	0.7	450	450	3.0
3	2.32	0.51	0.39	24	25.0	50.0	0.4	450	450	3.2
4	2.91	0.67	0.51	31	15.0	21.3	0.3	450	450	3.4
5	3.50	0.83	0.63	39	5.0	25.0	0.1	425	450	3.6
6	4.06	0.98	0.75	45	5.0	12.5	< 0.1	400	450	3.8
7	4.65	1.14	0.87	52	2.0	6.3	< 0.1	400	450	4.0
8	5.24	1.30	0.98	58	2.0	3.1	< 0.1	400	450	4.2
9	5.83	1.50	1.14	64	1.5	3.1	< 0.1	400	450	4.4
10	6.42	1.65	1.26	70	1.5	2.5	< 0.1	400	450	4.6
11	7.00	1.81	1.38	76	1.3	2.3	< 0.1	400	450	4.8
12	7.59	2.00	1.50	82	1.3	2.2	< 0.1	400	450	5.0

☀ Data applicable to LimitLink design only - AntiSquirm design is intended for axial movements only

## LimitLink™ Flexijoint®

Working Pressure vs. Temperature (Non-Shock)

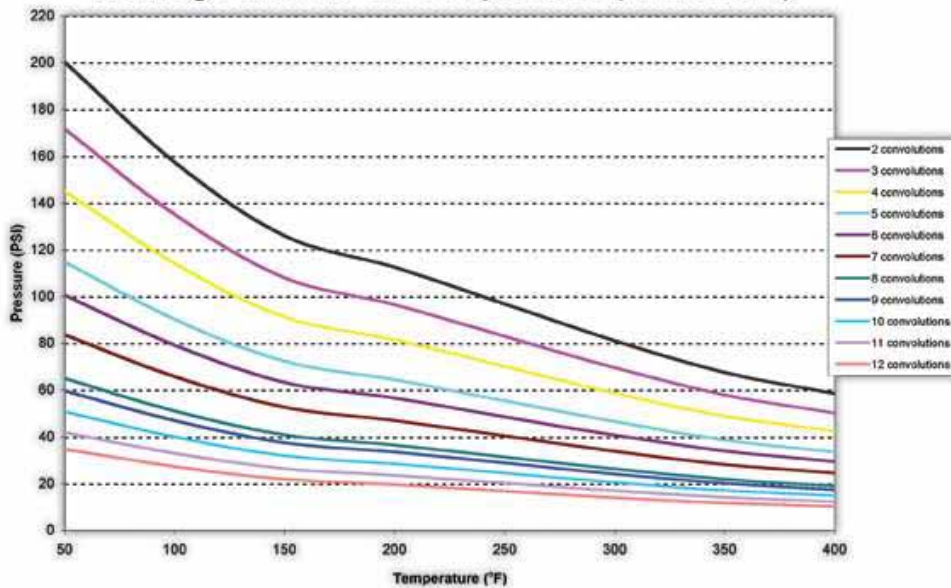

## AntiSquirm™ Flexijoint®

Working Pressure vs. Temperature (Non-Shock)

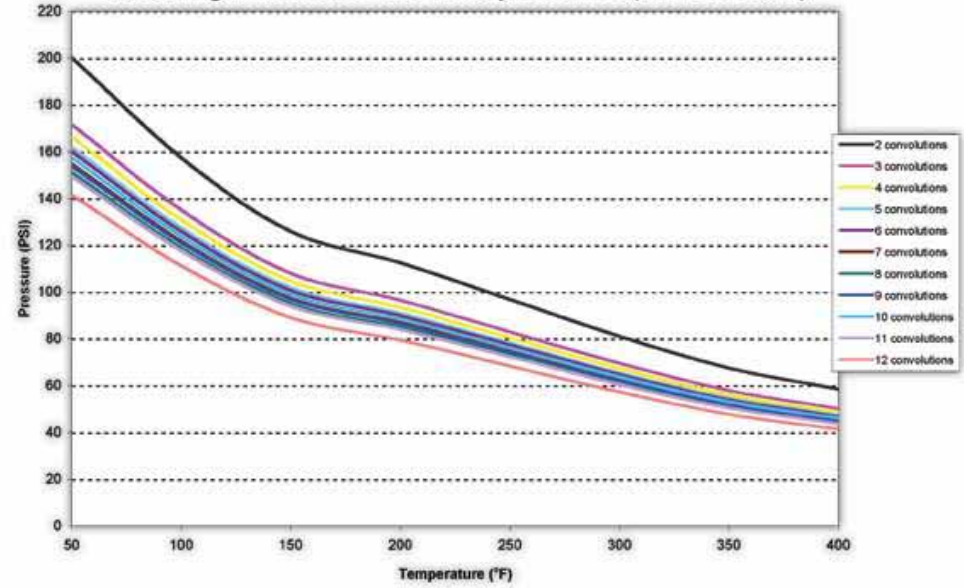

# FLEXI.50"INT<sup>®</sup>



Number of Convolutions	Length (in.)	Axial Movement (+/- in.)	Lateral Movement (+/- in.)	Angular Movement (deg)	Axial Spring Rate (lb./1/8 in.)	Lateral Spring Rate (lb./1/8 in.)	Angular Torque (in.-lb./deg)	Std. Full Vacuum Temp (°F)	Vacubands™ Full Vacuum Temp (°F)	Weight (lbs)
2	1.77	0.35	0.24	14	55.0	75.0	3.0	450	450	3.0
3	2.36	0.51	0.39	21	30.0	62.5	2.0	450	450	3.3
4	2.95	0.67	0.51	28	20.0	33.8	1.0	450	450	3.6
5	3.54	0.83	0.63	34	15.0	33.8	1.0	425	450	3.9
6	4.17	1.02	0.75	41	10.0	15.6	< 0.1	400	450	4.2
7	4.78	1.18	0.91	47	5.0	12.5	< 0.1	400	450	4.5
8	5.35	1.38	1.02	53	2.0	6.3	< 0.1	400	450	4.8
9	5.94	1.54	1.14	58	2.0	3.1	< 0.1	400	450	5.1
10	6.54	1.69	1.30	64	1.5	3.1	< 0.1	400	450	5.4
11	7.13	1.88	1.41	70	1.4	2.8	< 0.1	400	450	5.7
12	7.72	2.06	1.53	76	1.4	2.6	< 0.1	400	450	6.0

☀ Data applicable to LimitLink design only - AntiSquirm design is intended for axial movements only

## LimitLink™ Flexijoint<sup>®</sup>

Working Pressure vs. Temperature (Non-Shock)

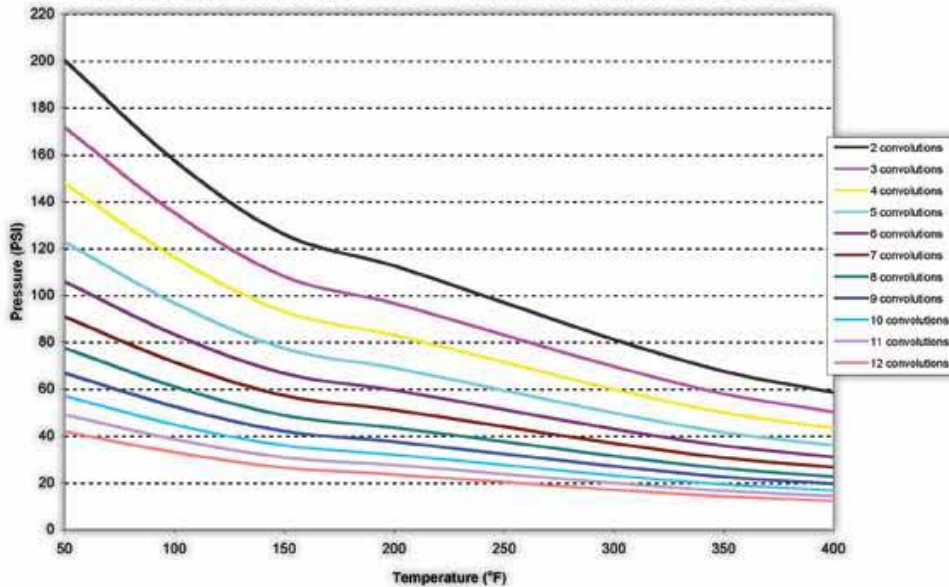

## AntiSquirm™ Flexijoint<sup>®</sup>

Working Pressure vs. Temperature (Non-Shock)

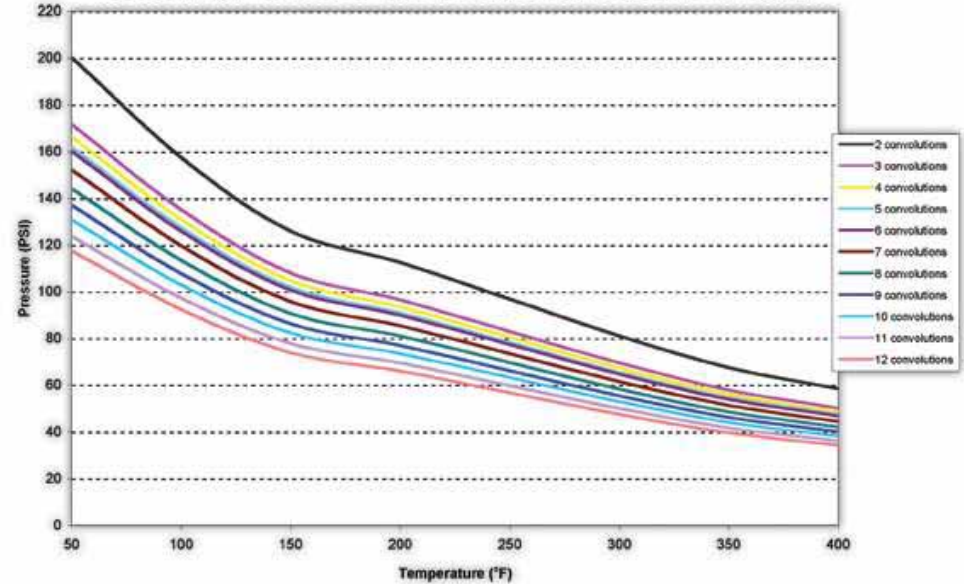

# FLEXIJOINT<sup>®</sup>



Number of Convolutions	Length (in.)	Axial Movement (+/- in.)	Lateral Movement (+/- in.)	Angular Movement (deg)	Axial Spring Rate (lb./1/8 in.)	Lateral Spring Rate (lb./1/8 in.)	Angular Torque (in.-lb./deg)	Std. Full Vacuum Temp (°F)	Vacubands™ Full Vacuum Temp (°F)	Weight (lbs)
2	1.89	0.35	0.28	12°	70.0	125.0	4.0	450	450	6.0
3	2.52	0.51	0.39	17°	42.0	87.0	3.0	450	450	6.4
4	3.11	0.71	0.51	23°	30.0	50.0	2.0	450	450	6.8
5	3.74	0.87	0.67	29°	25.0	44.0	1.0	425	450	7.2
6	4.37	1.06	0.83	34°	20.0	25.0	< 0.1	400	450	7.6
7	4.96	1.26	0.94	39°	15.0	22.0	< 0.1	400	450	8.0
8	5.59	1.46	1.06	44°	10.0	18.0	< 0.1	400	450	8.4
9	6.22	1.57	1.16	49°	10.0	12.0	< 0.1	400	450	8.8
10	6.85	1.77	1.34	54°	5.0	12.0	< 0.1	400	450	9.2
11	7.47	2.00	1.50	59°	3.7	9.8	< 0.1	400	450	9.6
12	8.09	2.19	1.66	64°	3.1	7.2	< 0.1	400	450	10.0

☀ Data applicable to LimitLink design only - AntiSquirm design is intended for axial movements only

## LimitLink™ Flexijoint<sup>®</sup>

Working Pressure vs. Temperature (Non-Shock)

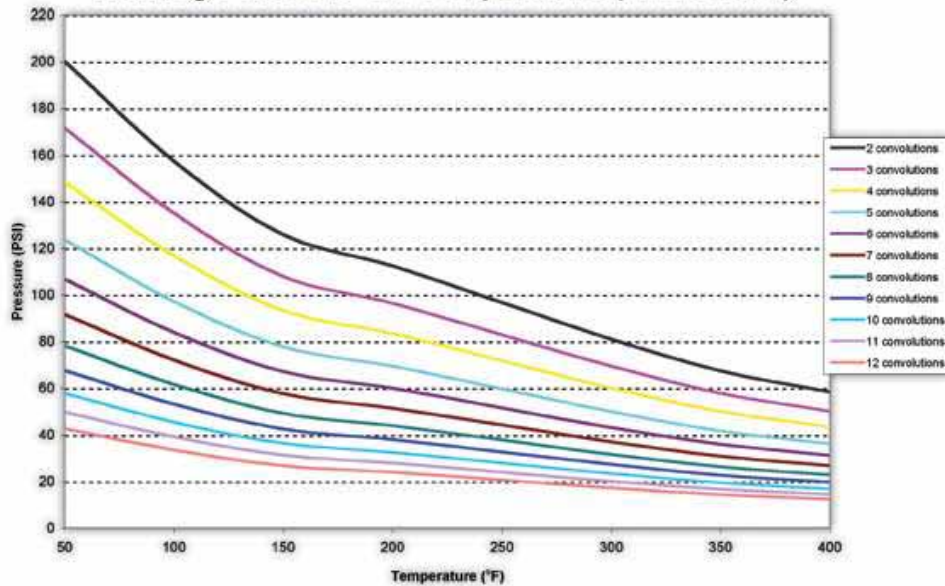

## AntiSquirm™ Flexijoint<sup>®</sup>

Working Pressure vs. Temperature (Non-Shock)

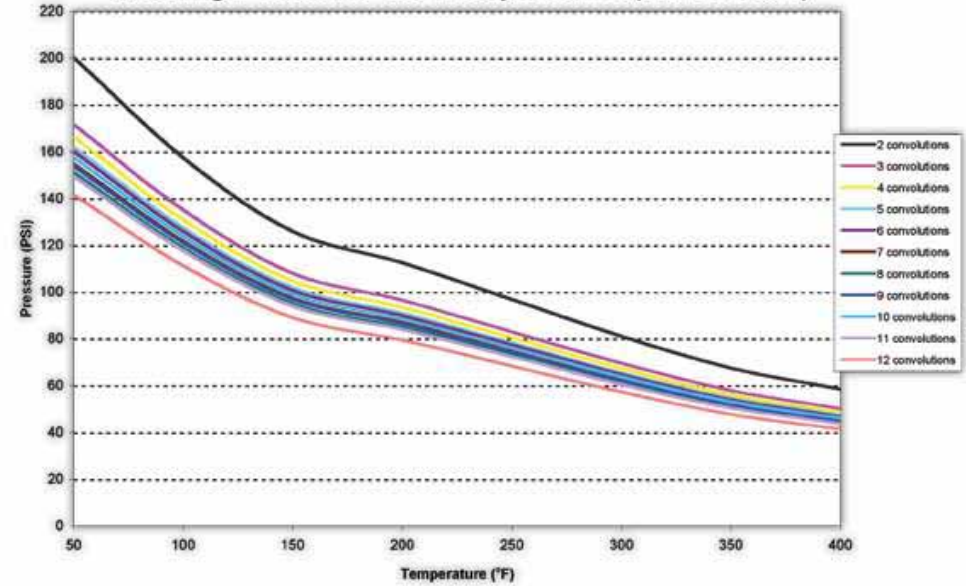

# FLEXIJOINT<sup>®</sup> 2.5"



Number of Convolutions	Length (in.)	Axial Movement (+/- in.)	Lateral Movement (+/- in.)	Angular Movement (deg)	Axial Spring Rate (lb./1/8 in.)	Lateral Spring Rate (lb./1/8 in.)	Angular Torque (in.-lb./deg)	Std. Full Vacuum Temp (°F)	Vacubands™ Full Vacuum Temp (°F)	Weight (lbs)
2	2.13	0.39	0.31	11°	80.0	150.0	7.0	425	450	9.0
3	2.80	0.59	0.47	17°	52.0	100.0	5.0	425	450	9.6
4	3.54	0.83	0.59	22°	40.0	62.5	4.0	425	450	10.2
5	4.25	0.98	0.75	28°	30.0	50.0	3.0	400	450	10.8
6	4.92	1.22	0.91	33°	25.0	31.3	1.0	400	450	11.4
7	5.67	1.42	1.06	38°	20.0	25.0	< 0.1	350	450	12.0
8	6.38	1.61	1.22	43°	18.0	18.8	< 0.1	350	450	12.6
9	7.05	1.81	1.38	48°	15.0	18.8	< 0.1	300	450	13.2
10	7.80	2.05	1.50	53°	10.0	18.8	< 0.1	300	450	13.8
11	8.50	2.25	1.66	58°	7.4	13.2	< 0.1	250	450	14.4
12	9.19	2.47	1.81	63°	6.2	10.5	< 0.1	250	450	15.0

☀ Data applicable to LimitLink design only - AntiSquirm design is intended for axial movements only

## LimitLink™ Flexijoint<sup>®</sup>

Working Pressure vs. Temperature (Non-Shock)

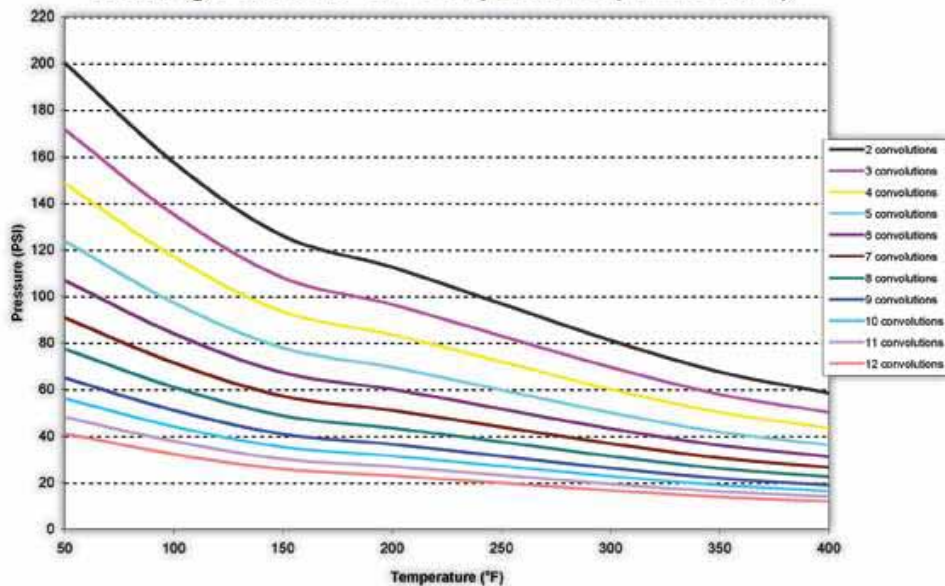

## AntiSquirm™ Flexijoint<sup>®</sup>

Working Pressure vs. Temperature (Non-Shock)

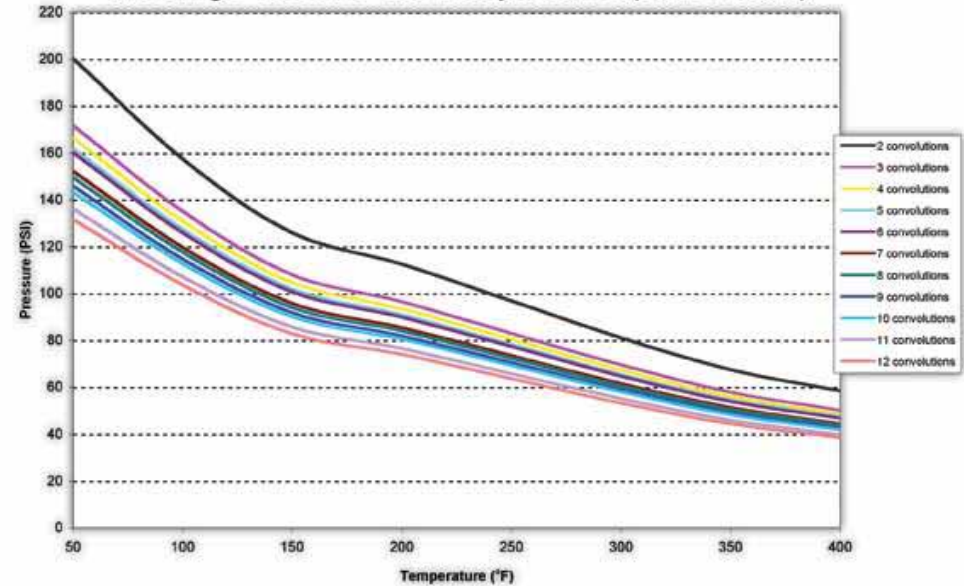

# FLEX3"JOINT®



Number of Convolutions	Length (in.)	Axial Movement (+/- in.)	Lateral Movement (+/- in.)	Angular Movement (deg.)	Axial Spring Rate (lb./1/8 in.)	Lateral Spring Rate (lb./1/8 in.)	Angular Torque (in.-lb./deg.)	Std. Full Vacuum Temp (°F)	Vacubands™ Full Vacuum Temp (°F)	Weight (lbs)
2	2.20	0.39	0.31	10	90.0	162.4	11.0	425	450	10.0
3	2.91	0.63	0.47	15	60.0	125.0	8.0	425	450	10.8
4	3.62	0.83	0.63	20	45.0	75.0	6.0	400	450	11.6
5	4.37	1.02	0.79	25	40.0	58.3	5.0	350	450	12.4
6	5.08	1.26	0.94	30	30.0	37.5	3.0	350	450	13.2
7	5.83	1.48	1.10	34	22.0	31.3	3.0	300	450	14.0
8	6.57	1.65	1.28	39	20.0	25.0	2.0	300	450	14.8
9	7.26	1.89	1.42	43	18.0	25.0	2.0	250	450	15.6
10	7.99	2.09	1.57	47	13.8	25.0	1.0	250	450	16.4
11	8.72	2.31	1.72	51	11.2	19.2	1.0	200	450	17.2
12	9.44	2.56	1.88	55	9.4	14.6	1.0	200	450	18.0

☀ Data applicable to LimitLink design only - AntiSquirm design is intended for axial movements only

## LimitLink™ Flexijoint®

Working Pressure vs. Temperature (Non-Shock)

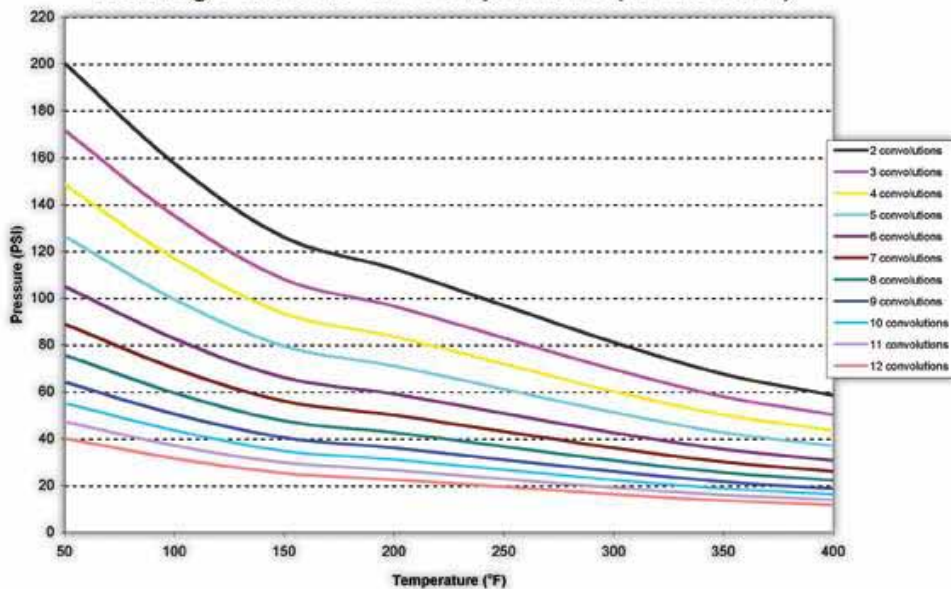

## AntiSquirm™ Flexijoint®

Working Pressure vs. Temperature (Non-Shock)

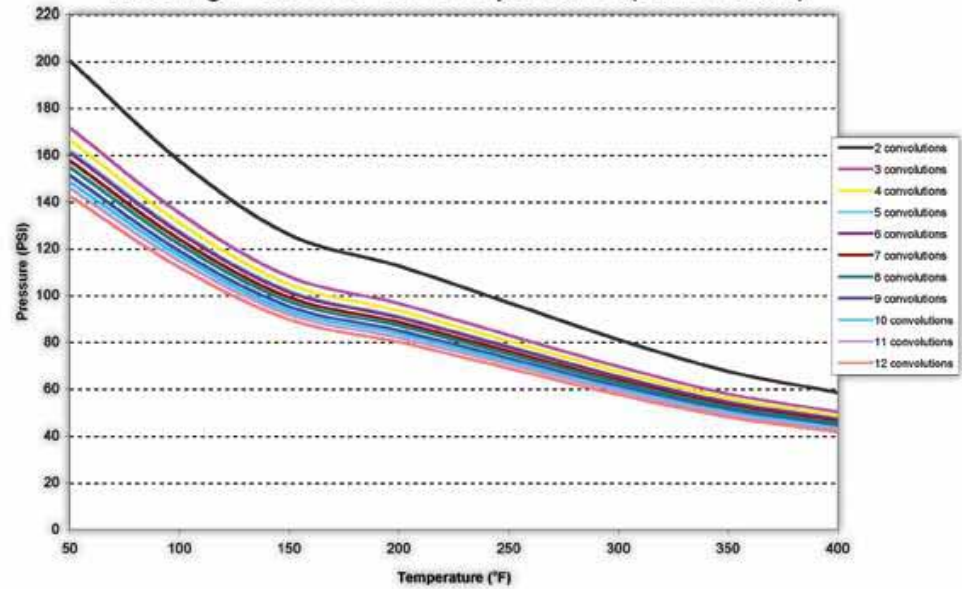

# FLEX4"JOINT®



Number of Convolutions	Length (in.)	Axial Movement (+/- in.)	Lateral Movement (+/- in.)	Angular Movement (deg)	Axial Spring Rate (lb./1/8 in.)	Lateral Spring Rate (lb./1/8 in.)	Angular Torque (in.-lb./deg)	Std. Full Vacuum Temp (°F)	Vacubands™ Full Vacuum Temp (°F)	Weight (lbs)
2	2.28	0.43	0.31	9	110.0	237.4	26	400	450	14.0
3	3.07	0.67	0.51	13	80.0	166.2	18	400	450	15.0
4	3.82	0.87	0.67	17	60.0	100.0	14	350	450	16.0
5	4.57	1.10	0.83	21	50.0	80.0	11	300	450	17.0
6	5.35	1.30	0.98	26	40.0	62.5	9	300	450	18.0
7	6.10	1.54	1.14	30	30.0	37.5	7	250	450	19.0
8	6.89	1.73	1.30	34	25.0	31.3	6	250	450	20.0
9	7.64	1.97	1.46	38	22.0	31.3	6	200	450	21.0
10	8.43	2.20	1.61	41	20.0	27.0	4	200	450	22.0
11	9.19	2.44	1.78	44	18.3	23.4	4	150	450	23.0
12	9.94	2.69	1.94	47	13.1	17.9	3	150	450	24.0

☀ Data applicable to LimitLink design only - AntiSquirm design is intended for axial movements only

## LimitLink™ Flexijoint®

Working Pressure vs. Temperature (Non-Shock)

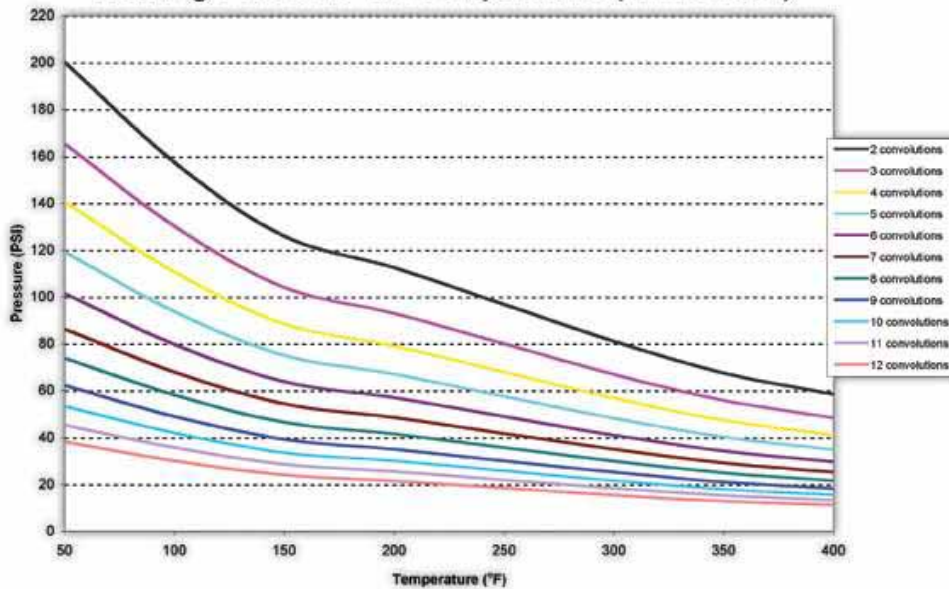

## AntiSquirm™ Flexijoint®

Working Pressure vs. Temperature (Non-Shock)

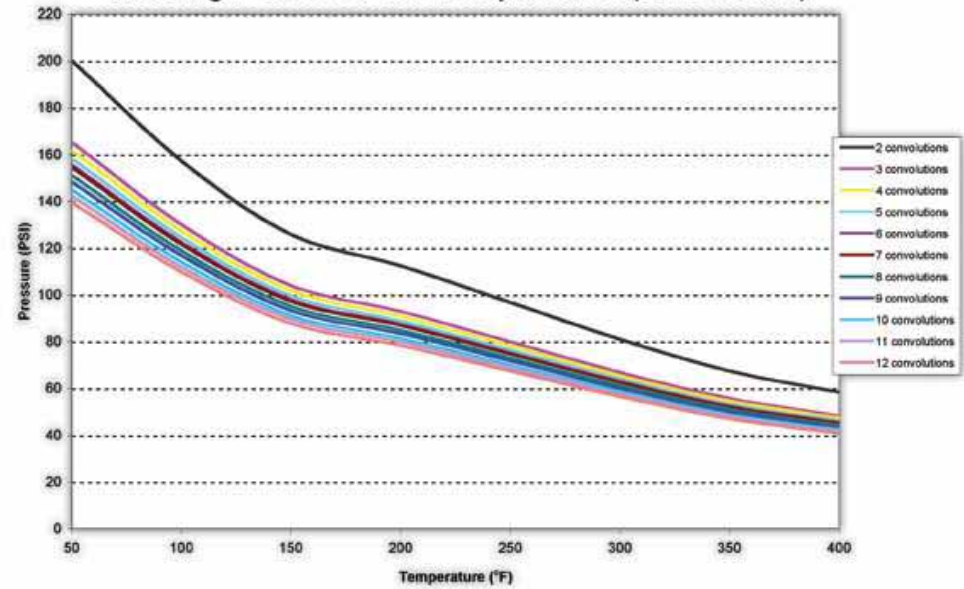

# FLEX5" JOINT®



Number of Convolutions	Length (in.)	Axial Movement (+/- in.)	Lateral Movement (+/- in.)	Angular Movement (deg)	Axial Spring Rate (lb./1/8 in.)	Lateral Spring Rate (lb./1/8 in.)	Angular Torque (in.-lb./deg)	Std. Full Vacuum Temp (°F)	Vacubands™ Full Vacuum Temp (°F)	Weight (lbs)
2	2.41	0.47	0.34	8	126	286	47	400	450	17.0
3	3.22	0.69	0.53	11	92	219	33	350	450	18.0
4	4.03	0.91	0.69	15	72	153	26	300	450	19.0
5	4.84	1.16	0.88	19	60	100	21	250	450	20.0
6	5.63	1.38	1.03	23	49	81	17	250	450	21.0
7	6.44	1.63	1.22	26	39	63	13	200	450	22.0
8	7.25	1.84	1.38	30	35	53	11	200	450	23.0
9	8.06	2.06	1.56	33	30	45	11	150	450	24.0
10	8.84	2.31	1.72	37	27	43	9	150	450	25.0
11	9.68	2.58	1.88	40	22	42	8	150	450	26.0
12	10.44	2.81	2.09	44	19	41	8	150	450	27.0

☀ Data applicable to LimitLink design only - AntiSquirm design is intended for axial movements only

## LimitLink™ Flexijoint®

Working Pressure vs. Temperature (Non-Shock)

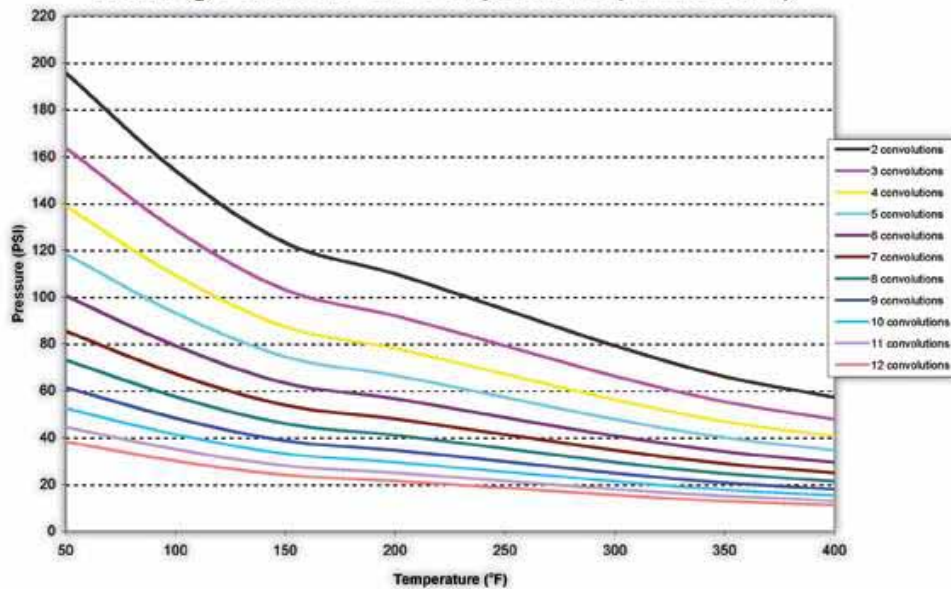

## AntiSquirm™ Flexijoint®

Working Pressure vs. Temperature (Non-Shock)

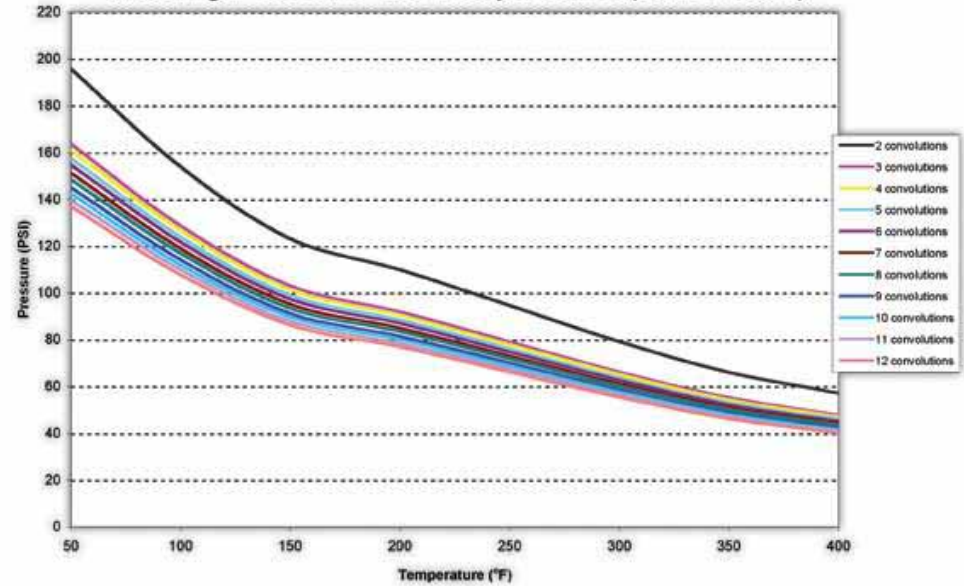



# FLEX 6" JOINT®



Number of Convolutions	Length (in.)	Axial Movement (+/- in.)	Lateral Movement (+/- in.)	Angular Movement (deg)	Axial Spring Rate (lb./1/8 in.)	Lateral Spring Rate (lb./1/8 in.)	Angular Torque (in.-lb./deg)	Std. Full Vacuum Temp (°F)	Vacubands™ Full Vacuum Temp (°F)	Weight (lbs)
2	2.53	0.47	0.38	7	146	350	77	320	450	21.0
3	3.38	0.72	0.53	10	105	269	56	300	450	23.0
4	4.19	0.97	0.72	14	83	187	45	250	450	25.0
5	5.03	1.19	0.91	17	69	144	37	200	450	27.0
6	5.88	1.44	1.09	20	56	105	31	200	450	29.0
7	6.72	1.69	1.25	24	45	88	22	150	450	31.0
8	7.56	1.91	1.44	27	40	73	21	100	450	33.0
9	8.41	2.16	1.63	30	35	63	18	CF	450	35.0
10	9.25	2.41	1.81	33	31	61	16	CF	450	37.0
11	10.09	2.68	2.00	36	27	60	14	CF	450	39.0
12	10.94	2.91	2.19	39	23	59	12	CF	450	41.0

☀ Data applicable to LimitLink design only - AntiSquirm design is intended for axial movements only

## LimitLink™ Flexijoint®

Working Pressure vs. Temperature (Non-Shock)

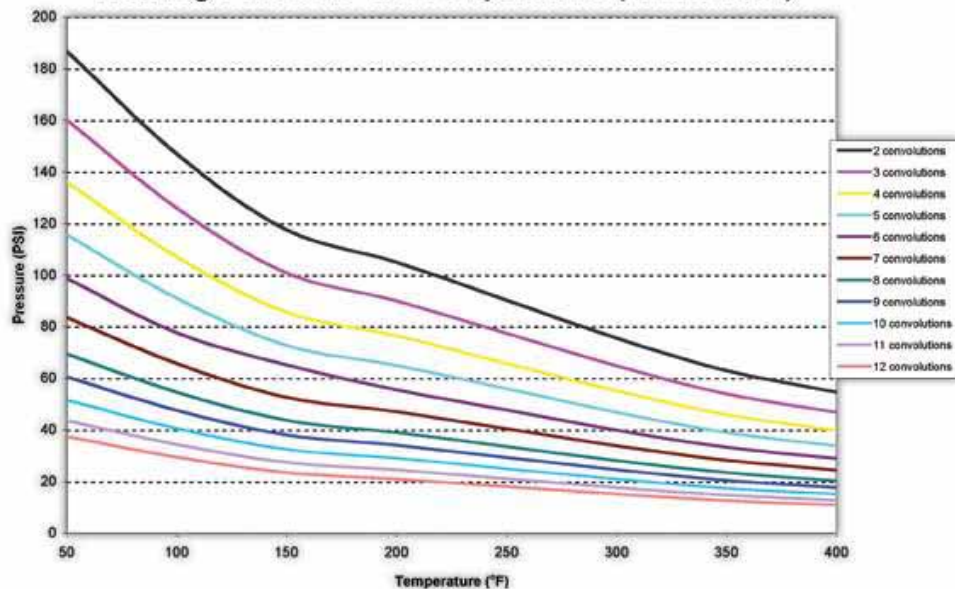

## AntiSquirm™ Flexijoint®

Working Pressure vs. Temperature (Non-Shock)

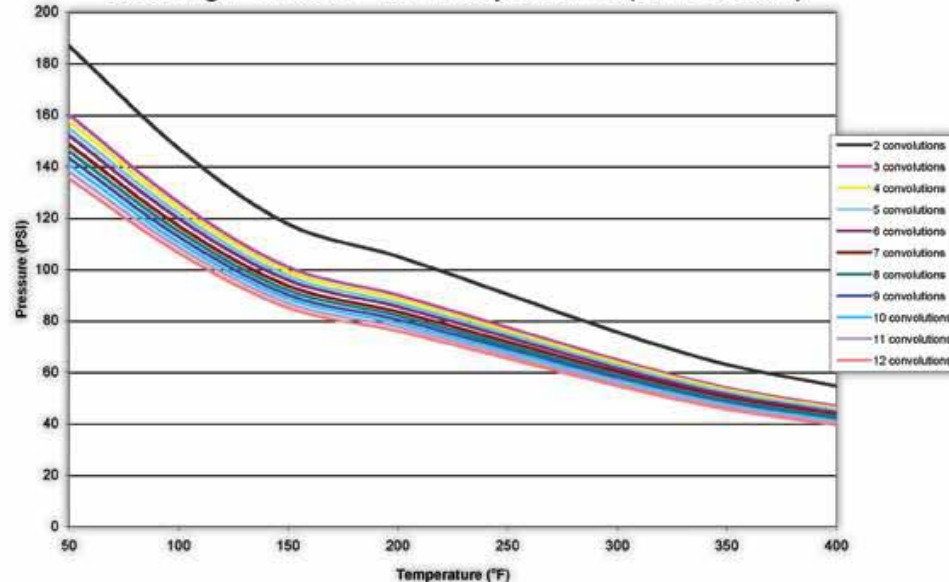

# FLEX 8" JOINT®



Number of Convolutions	Length (in.)	Axial Movement (+/- in.)	Lateral Movement (+/- in.)	Angular Movement (deg)	Axial Spring Rate (lb/1/8 in.)	Lateral Spring Rate (lb/1/8 in.)	Angular Torque (in.-lb./deg)	Std. Full Vacuum Temp (°F)	Vacubands™ Full Vacuum Temp (°F)	Weight (lbs)
2	2.75	0.53	0.41	6	173	475	166	250	450	32.0
3	3.66	0.78	0.59	9	122	350	116	200	450	35.0
4	4.59	1.06	0.78	12	100	270	95	200	450	38.0
5	5.50	1.31	0.97	15	80	212	74	150	450	41.0
6	6.41	1.56	1.19	18	65	175	59	100	450	44.0
7	7.34	1.84	1.38	21	58	150	53	CF	450	47.0
8	8.25	2.09	1.56	24	50	125	47	CF	450	50.0
9	9.16	2.34	1.78	27	45	112	40	CF	450	53.0
10	10.09	2.63	1.97	29	40	100	36	CF	450	56.0
11	11.00	2.91	2.16	31	35	93	35	CF	450	59.0
12	11.94	3.19	2.34	33	30	86	31	CF	450	62.0

☀ Data applicable to LimitLink design only - AntiSquirm design is intended for axial movements only

## LimitLink™ Flexijoint®

Working Pressure vs. Temperature (Non-Shock)

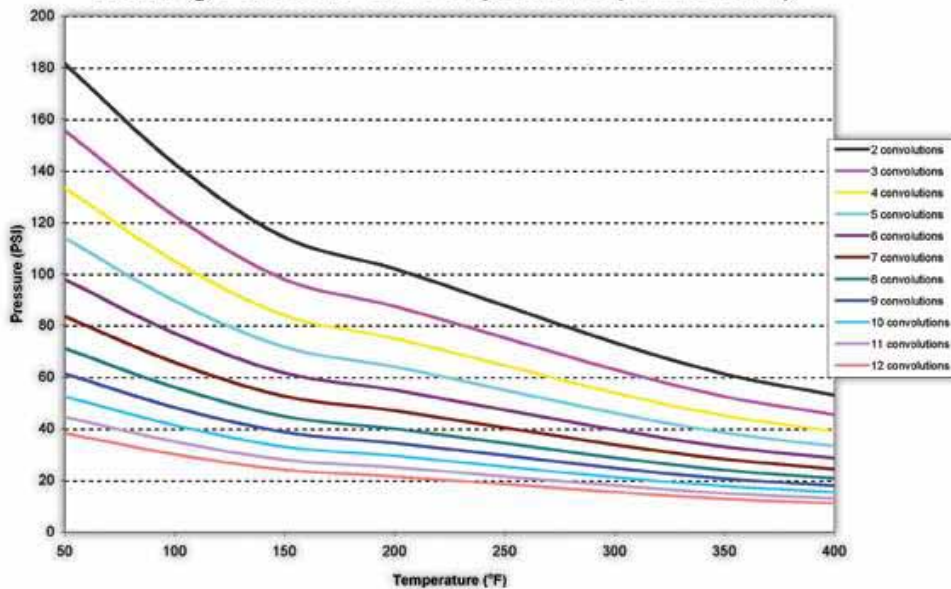

## AntiSquirm™ Flexijoint®

Working Pressure vs. Temperature (Non-Shock)

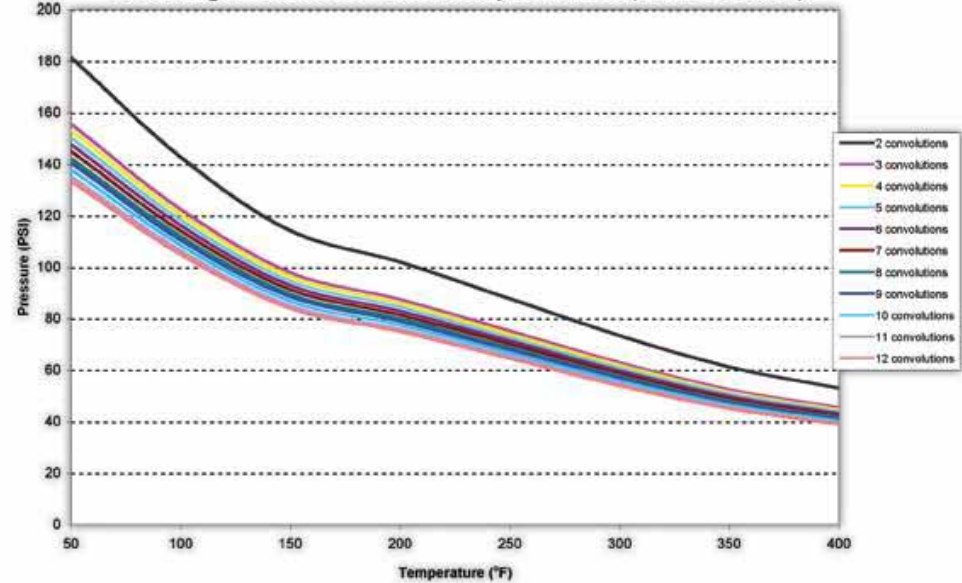

# FLEX10"®



Number of Convolutions	Length (in.)	Axial Movement (+/- in.)	Lateral Movement (+/- in.)	Angular Movement (deg)	Axial Spring Rate (lb./1/8 in.)	Lateral Spring Rate (lb./1/8 in.)	Angular Torque (in.-lb./deg)	Std. Full Vacuum Temp (°F)	Vacubands™ Full Vacuum Temp (°F)	Weight (lbs)
2	2.97	0.56	0.44	5	198	594	290	200	450	44.0
3	3.94	0.84	0.63	8	140	437	209	200	450	48.0
4	4.94	1.13	0.84	11	112	344	168	150	450	52.0
5	5.94	1.41	1.06	13	90	287	133	100	450	56.0
6	6.91	1.69	1.28	16	75	237	110	CF	450	60.0
7	7.91	1.97	1.47	18	62	206	93	CF	450	64.0
8	8.88	2.25	1.69	21	57	175	81	CF	450	68.0
9	9.88	2.53	1.91	23	52	162	64	CF	450	72.0
10	10.84	2.81	2.13	26	47	150	58	CF	450	76.0
11	11.84	3.09	2.34	28	42	137	52	CF	450	80.0
12	12.81	3.38	2.56	31	36	125	46	CF	450	84.0

☀ Data applicable to LimitLink design only - AntiSquirm design is intended for axial movements only

## LimitLink™ Flexijoint®

Working Pressure vs. Temperature (Non-Shock)

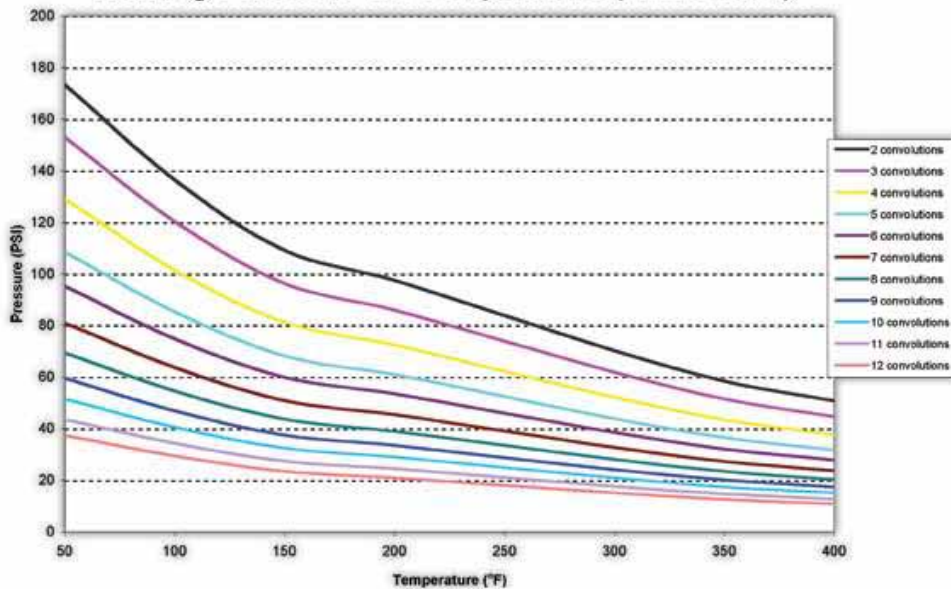

## AntiSquirm™ Flexijoint®

Working Pressure vs. Temperature (Non-Shock)

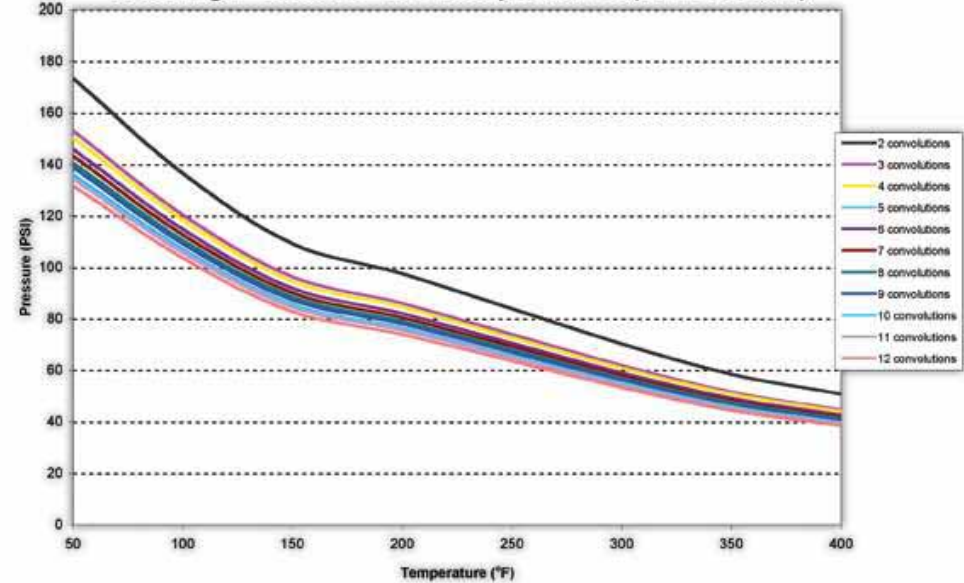

# FLEX12"®



Number of Convolutions	Length (in.)	Axial Movement (+/- in.)	Lateral Movement (+/- in.)	Angular Movement (deg)	Axial Spring Rate (lb./1/8 in.)	Lateral Spring Rate (lb./1/8 in.)	Angular Torque (in.-lb./deg)	Std. Full Vacuum Temp (°F)	Vacubands™ Full Vacuum Temp (°F)	Weight (lbs)
2	3.19	0.59	0.47	5	218	713	462	150	450	68.0
3	4.25	0.91	0.69	7	152	525	281	120	450	73.0
4	5.31	1.22	0.91	10	121	425	261	100	450	78.0
5	6.38	1.53	1.13	12	96	350	211	CF	450	83.0
6	7.44	1.81	1.38	14	81	306	170	CF	450	88.0
7	8.50	2.13	1.59	17	70	272	140	CF	450	93.0
8	9.56	2.44	1.81	19	62	230	130	CF	450	98.0
9	10.63	2.75	2.06	22	56	212	120	CF	450	103.0
10	11.72	3.03	2.28	24	51	193	110	CF	450	108.0
11	12.81	3.34	2.50	26	46	175	99	CF	450	113.0
12	13.88	3.66	2.72	28	41	163	88	CF	450	118.0

⚠ Data applicable to LimitLink design only - AntiSquirm design is intended for axial movements only

## LimitLink™ Flexijoint®

Working Pressure vs. Temperature (Non-Shock)

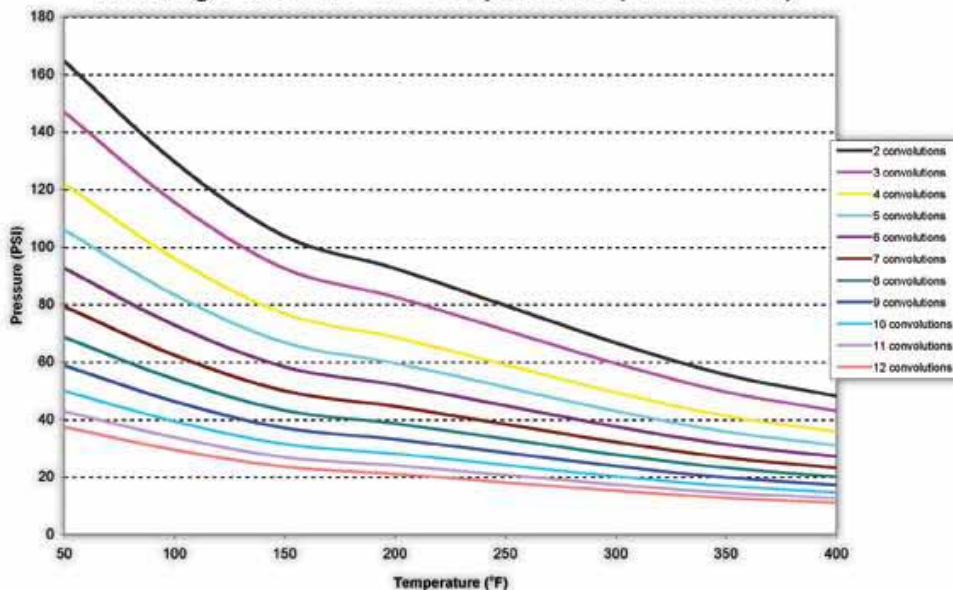

## AntiSquirm™ Flexijoint®

Working Pressure vs. Temperature (Non-Shock)

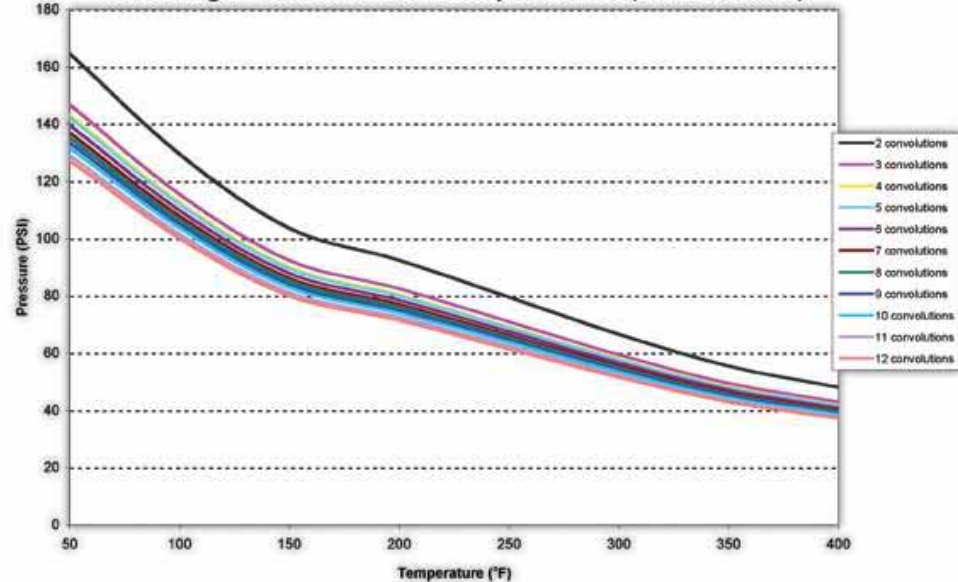

# FLEX14"®



Number of Convolutions	Length (in.)	Axial Movement (+/- in.)	Lateral Movement (+/- in.)	Angular Movement (deg)	Axial Spring Rate (lb/1/8 in.)	Lateral Spring Rate (lb/1/8 in.)	Angular Torque (in.-lb./deg)	Std. Full Vacuum Temp (°F)	Vacubands™ Full Vacuum Temp (°F)	Weight (lbs)
2	3.38	0.63	0.47	5	227	835	654	120	450	88.0
3	4.47	0.97	0.72	7	160	612	462	CF	450	95.0
4	5.59	1.28	0.97	9	127	494	376	CF	450	102.0
5	6.72	1.59	1.19	12	101	425	287	CF	450	109.0
6	7.84	1.91	1.44	14	88	369	239	CF	450	116.0
7	8.97	2.25	1.69	16	72	325	207	CF	450	123.0
8	10.09	2.56	1.91	19	66	287	183	CF	450	130.0
9	11.19	2.88	2.16	21	60	262	175	CF	450	137.0
10	12.31	3.19	2.41	23	54	237	159	CF	450	144.0
11	13.44	3.50	2.66	25	49	210	143	CF	450	151.0
12	14.56	3.81	2.91	27	43	194	128	CF	450	158.0

☀ Data applicable to LimitLink design only - AntiSquirm design is intended for axial movements only

## LimitLink™ Flexijoint®

Working Pressure vs. Temperature (Non-Shock)

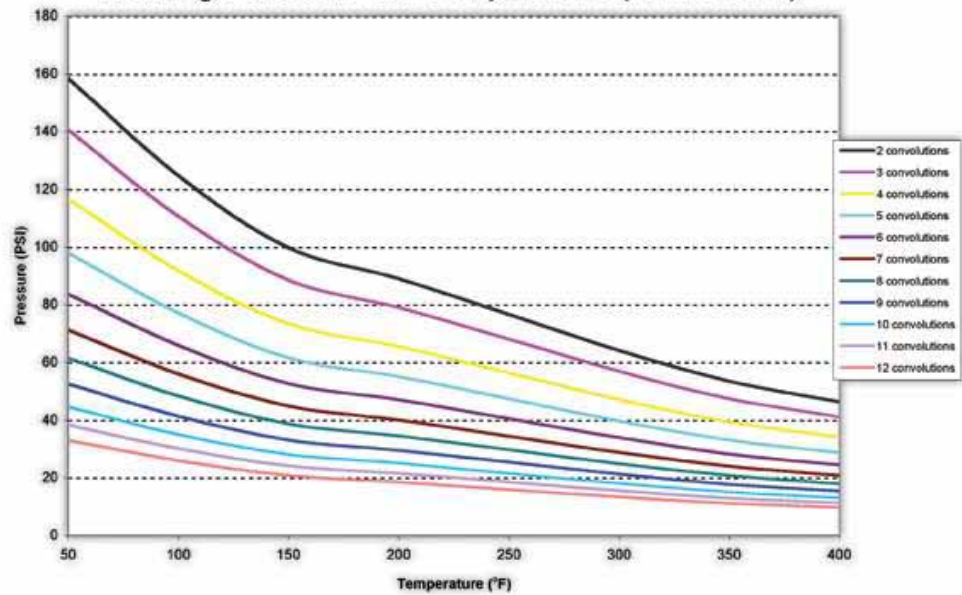

## AntiSquirm™ Flexijoint®

Working Pressure vs. Temperature (Non-Shock)

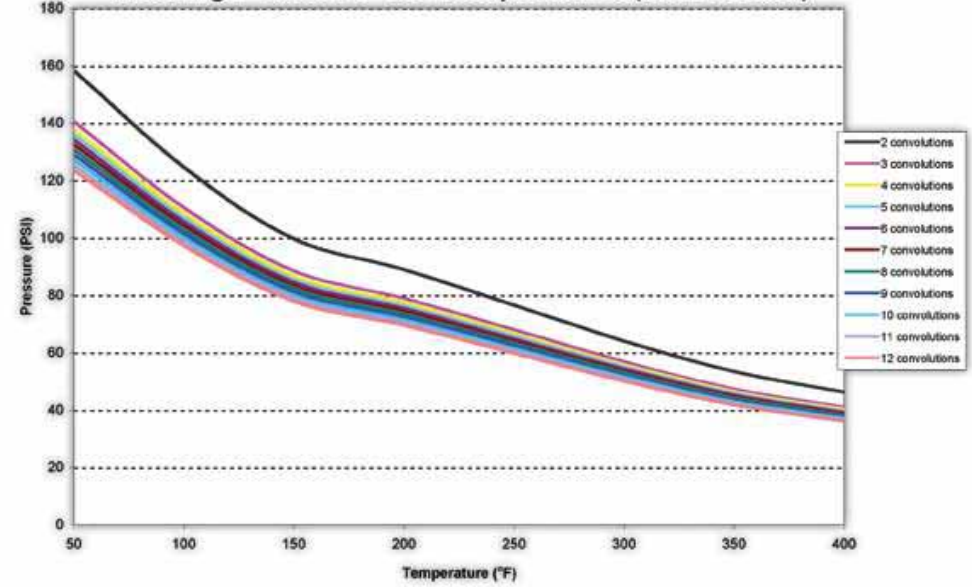

# FLEX16"®



Number of Convolutions	Length (in.)	Axial Movement (+/- in.)	Lateral Movement (+/- in.)	Angular Movement (deg)	Axial Spring Rate (lb/1/8 in.)	Lateral Spring Rate (lb/1/8 in.)	Angular Torque (in.-lb./deg)	Std. Full Vacuum Temp (°F)	Vacubands™ Full Vacuum Temp (°F)	Weight (lbs)
2	3.69	0.69	0.53	5	240	956	857	120	450	117.0
3	4.91	1.06	0.78	7	168	706	643	CF	450	126.0
4	6.13	1.41	1.06	9	135	575	500	CF	450	135.0
5	7.34	1.75	1.31	11	106	500	428	CF	450	144.0
6	8.56	2.09	1.56	13	93	437	333	CF	450	153.0
7	9.81	2.44	1.84	16	78	381	285	CF	450	162.0
8	11.03	2.81	2.09	18	71	337	262	CF	450	171.0
9	12.25	3.16	2.38	20	64	312	238	CF	450	180.0
10	13.47	3.50	2.63	22	56	282	214	CF	450	189.0
11	14.69	3.88	2.88	24	50	262	192	CF	450	198.0
12	15.94	4.25	3.13	26	44	237	173	CF	450	207.0

☀ Data applicable to LimitLink design only - AntiSquirm design is intended for axial movements only

## LimitLink™ Flexijoint®

Working Pressure vs. Temperature (Non-Shock)

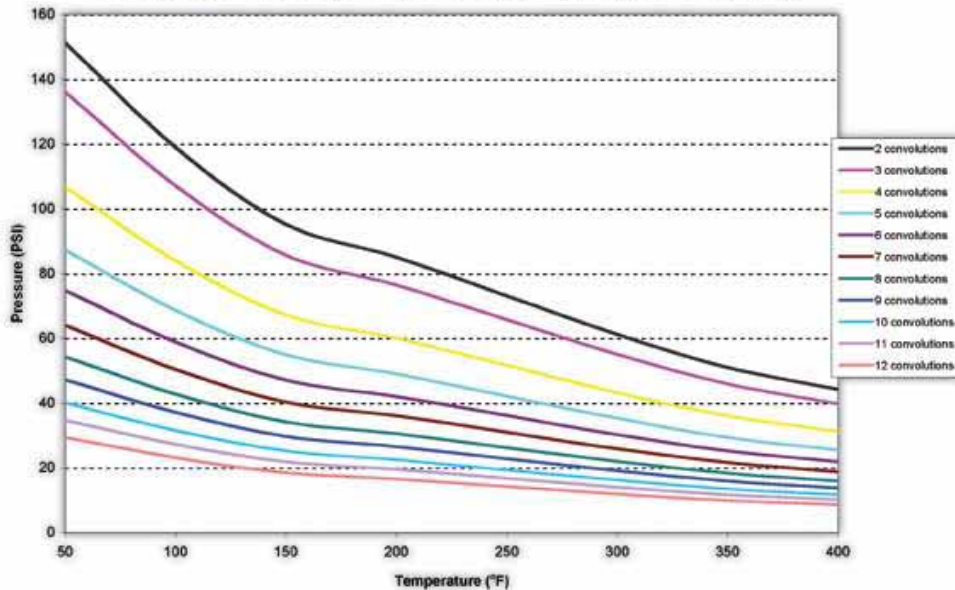

## AntiSquirm™ Flexijoint®

Working Pressure vs. Temperature (Non-Shock)

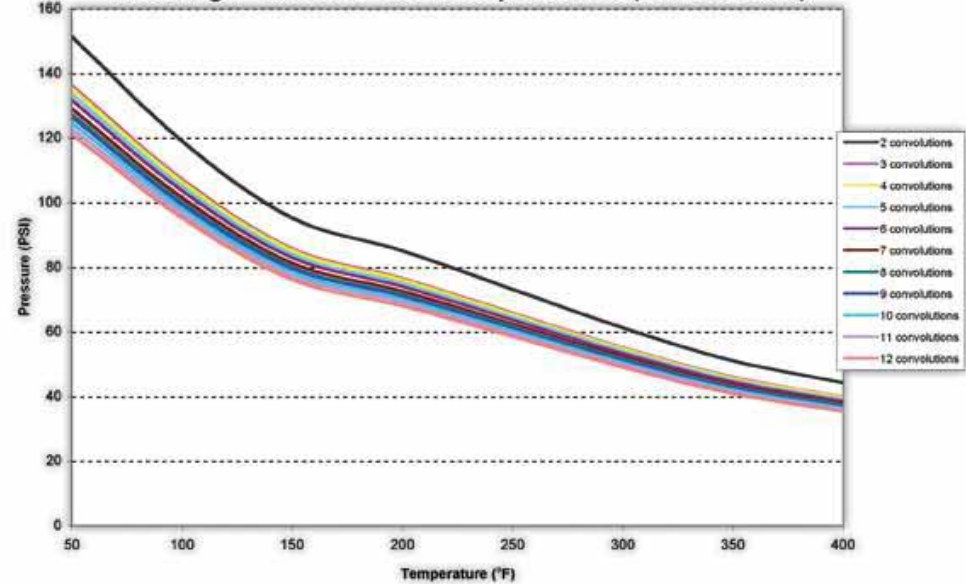

# FLEX 1.8" <sup>®</sup>



Number of Convolutions	Length (in.)	Axial Movement (+/- in.)	Lateral Movement (+/- in.)	Angular Movement (deg)	Axial Spring Rate (lb./1/8 in.)	Lateral Spring Rate (lb./1/8 in.)	Angular Torque (in.-lb./deg)	Std. Full Vacuum Temp (°F)	Vacubands™ Full Vacuum Temp (°F)	Weight (lbs)
2	4.00	0.75	0.56	4	252	1068	1187	100	450	132.0
3	5.34	1.16	0.88	7	173	788	848	CF	450	144.0
4	6.69	1.53	1.16	9	140	640	678	CF	450	156.0
5	8.03	1.91	1.44	11	108	563	575	CF	450	168.0
6	9.34	2.28	1.72	13	95	500	441	CF	450	180.0
7	10.69	2.69	2.00	15	79	437	373	CF	450	192.0
8	12.03	3.06	2.28	17	74	390	356	CF	450	204.0
9	13.38	3.44	2.53	20	66	350	339	CF	450	216.0
10	14.72	3.81	2.88	22	60	325	271	CF	450	228.0
11	16.06	4.19	3.16	24	53	300	244	CF	450	240.0
12	17.41	4.56	3.44	26	46	275	219	CF	450	252.0

☀ Data applicable to LimitLink design only - AntiSquirm design is intended for axial movements only

## LimitLink™ Flexijoint®

Working Pressure vs. Temperature (Non-Shock)

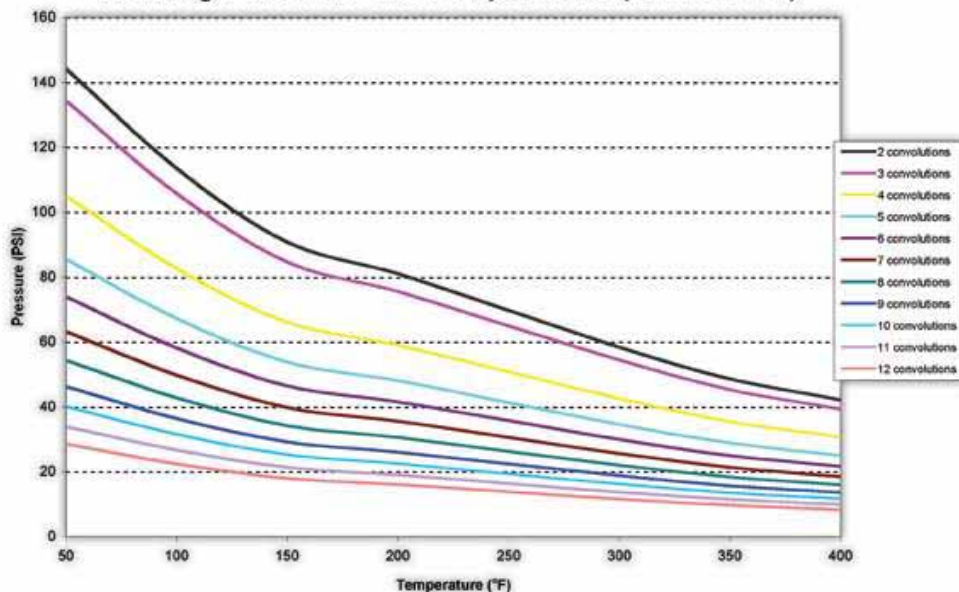

## AntiSquirm™ Flexijoint®

Working Pressure vs. Temperature (Non-Shock)

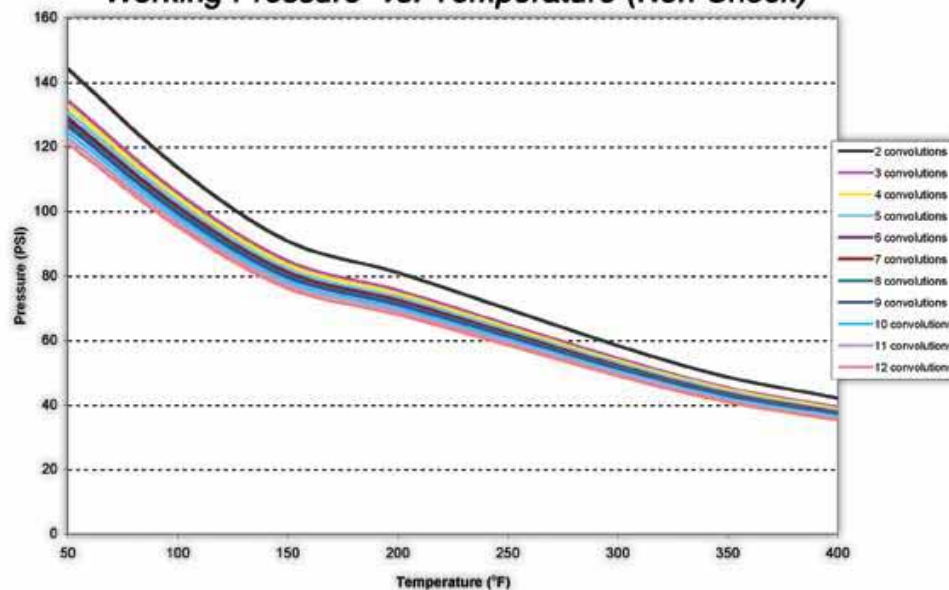

# FLEX20"®



Number of Convolutions	Length (in.)	Axial Movement (+/- in.)	Lateral Movement (+/- in.)	Angular Movement (deg)	Axial Spring Rate (lb./1/8 in.)	Lateral Spring Rate (lb./1/8 in.)	Angular Torque (in.-lb./deg)	Std. Full Vacuum Temp (°F)	Vacubands™ Full Vacuum Temp (°F)	Weight (lbs)
2	4.16	0.78	0.59	4	258	1187	1535	100	450	161.0
3	5.53	1.19	0.91	6	178	875	1070	CF	450	175.0
4	6.94	1.59	1.19	8	141	717	837	CF	450	189.0
5	8.31	1.97	1.50	10	110	631	651	CF	450	203.0
6	9.69	2.38	1.78	12	96	560	558	CF	450	217.0
7	11.09	2.78	2.09	14	81	493	502	CF	450	231.0
8	12.47	3.16	2.38	16	74	437	465	CF	450	245.0
9	13.88	3.56	2.69	18	68	397	418	CF	450	259.0
10	15.25	3.97	2.97	20	61	362	372	CF	450	273.0
11	16.63	4.38	3.31	22	55	337	331	CF	450	287.0
12	18.00	4.81	3.63	24	49	306	295	CF	450	301.0

☀ Data applicable to LimitLink design only - AntiSquirm design is intended for axial movements only

## LimitLink™ Flexijoint®

Working Pressure vs. Temperature (Non-Shock)

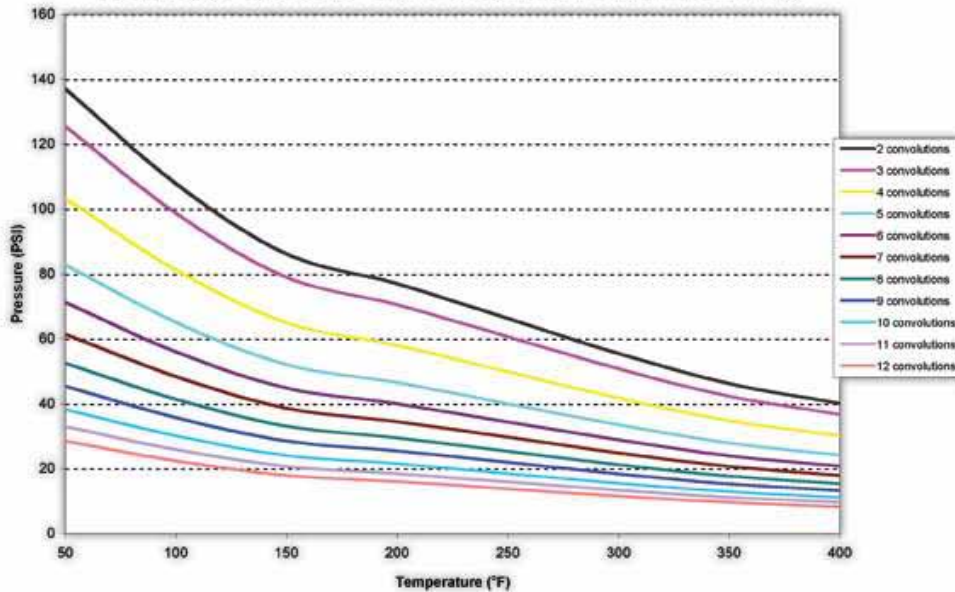

## AntiSquirm™ Flexijoint®

Working Pressure vs. Temperature (Non-Shock)

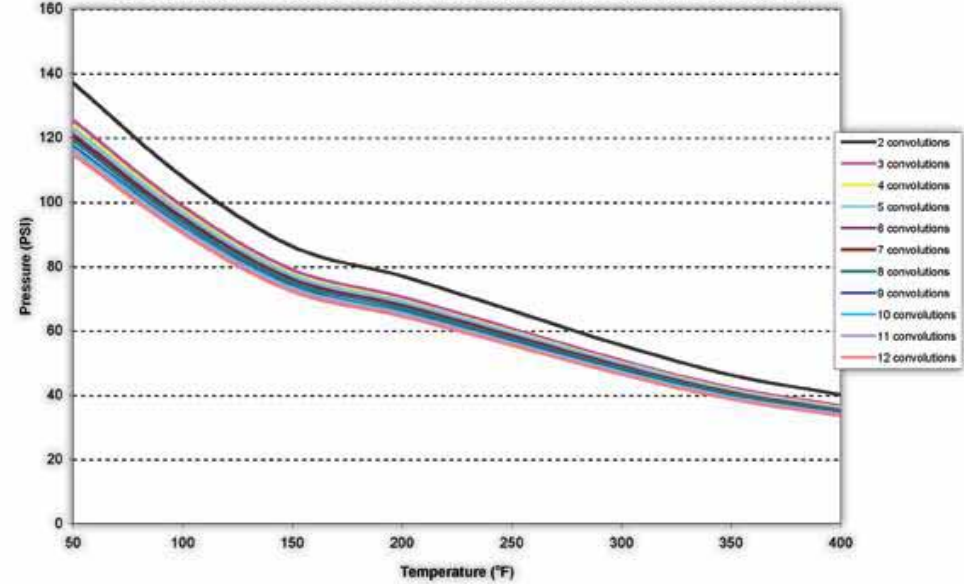



# FLEX24"®



Number of Convolutions	Length (in.)	Axial Movement (+/- in.)	Lateral Movement (+/- in.)	Angular Movement (deg)	Axial Spring Rate (lb./1/8 in.)	Lateral Spring Rate (lb./1/8 in.)	Angular Torque (in.-lb./deg)	Std. Full Vacuum Temp (°F)	Vacubands™ Full Vacuum Temp (°F)	Weight (lbs)
2	4.66	0.88	0.66	4	266	1425	2251	100	450	230.0
3	6.22	1.34	1.00	5	181	1062	1527	CF	450	251.0
4	7.78	1.78	1.34	8	145	875	1206	CF	450	272.0
5	9.31	2.22	1.66	10	112	777	964	CF	450	293.0
6	10.88	2.66	2.00	12	100	693	884	CF	450	314.0
7	12.22	3.09	2.34	14	88	613	723	CF	450	335.0
8	14.00	3.56	2.66	15	80	550	691	CF	450	356.0
9	15.53	4.00	3.00	17	72	494	643	CF	450	377.0
10	17.09	4.44	3.34	19	65	450	562	CF	450	386.0
11	18.63	4.88	3.69	21	58	407	505	CF	450	419.0
12	20.19	5.31	4.06	23	50	375	450	CF	450	440.0

☀ Data applicable to LimitLink design only - AntiSquirm design is intended for axial movements only

## LimitLink™ Flexijoint®

Working Pressure vs. Temperature (Non-Shock)

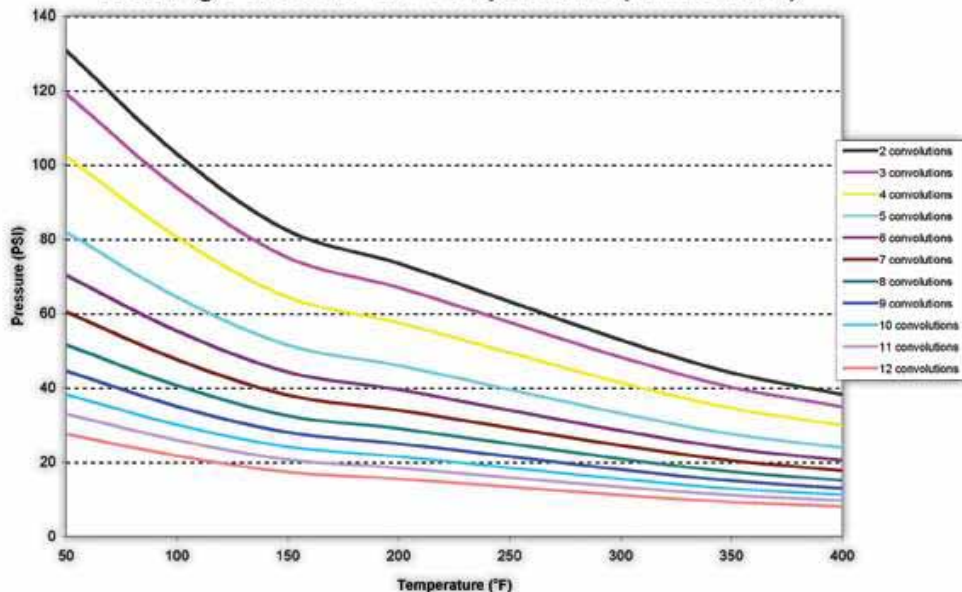

## AntiSquirm™ Flexijoint®

Working Pressure vs. Temperature (Non-Shock)

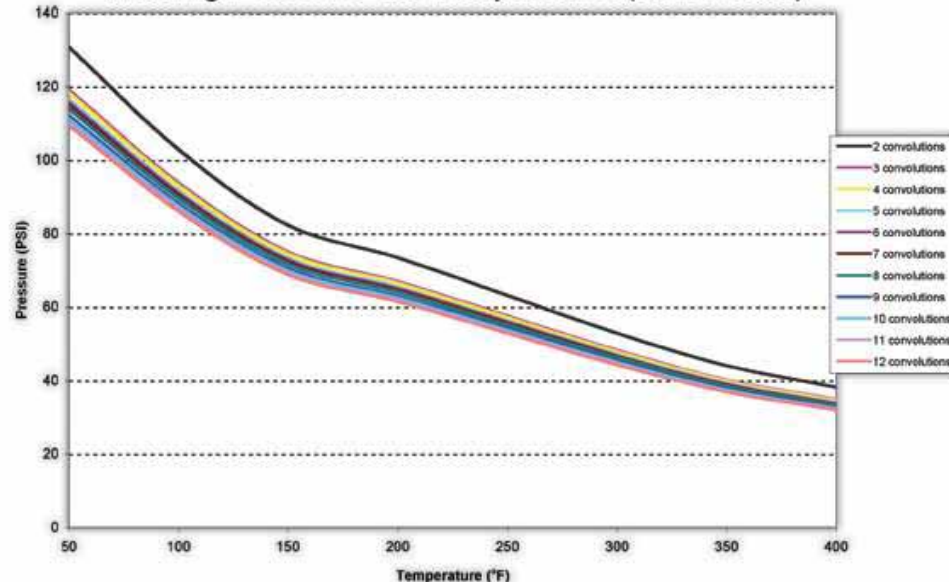

# FLEX28"®



Number of Convolutions	Length (in.)	Axial Movement (+/- in.)	Lateral Movement (+/- in.)	Angular Movement (deg)	Axial Spring Rate (lb./1/8 in.)	Lateral Spring Rate (lb./1/8 in.)	Angular Torque (in.-lb./deg)	Std. Full Vacuum Temp (°F)	Vacubands™ Full Vacuum Temp (°F)	Weight (lbs)
2	5.12	1.00	0.75	4	267	1624	2931	CF	450	350
3	6.89	1.50	1.14	6	182	1212	2942	CF	450	376
4	8.54	2.00	1.46	8	146	1012	2299	CF	450	403
5	10.31	2.44	1.81	10	113	906	1871	CF	450	431
6	12.00	2.95	2.20	12	100	813	1832	CF	450	458
7	13.74	3.43	2.56	14	89	725	1461	CF	450	484
8	15.43	3.94	2.95	15	81	650	1350	CF	450	510
9	17.20	4.46	3.39	17	73	588	1222	CF	450	538
10	18.86	4.88	3.70	19	66	531	1122	CF	450	565
11	20.63	5.38	4.05	21	59	470	1010	CF	450	591
12	22.40	5.87	4.44	24	51	418	899	CF	450	617

☛ Data applicable to LimitLink design only - AntiSquirm design is intended for axial movements only

## LimitLink™ Flexijoint®

Working Pressure vs. Temperature (Non-Shock)

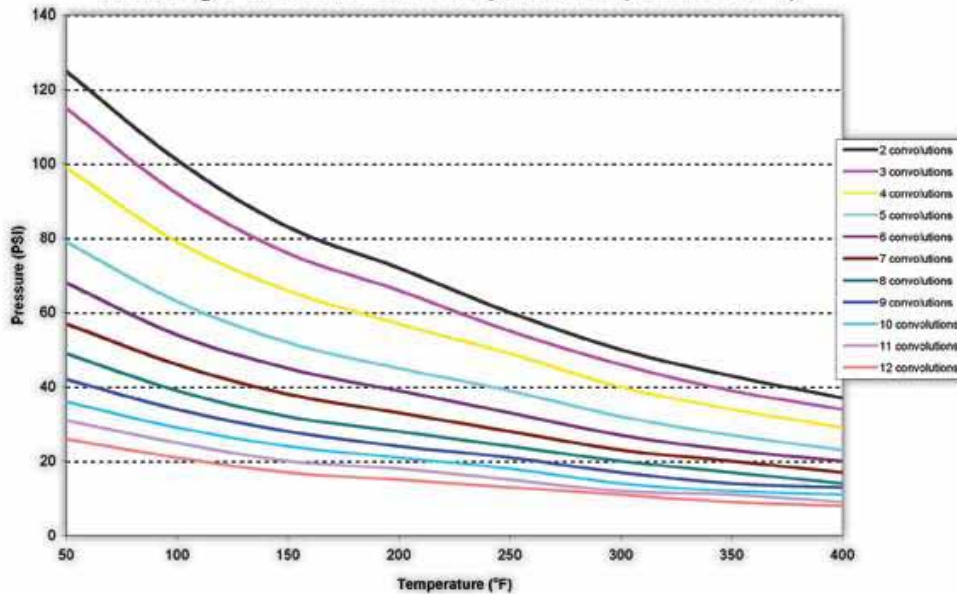

## AntiSquirm™ Flexijoint®

Working Pressure vs. Temperature (Non-Shock)

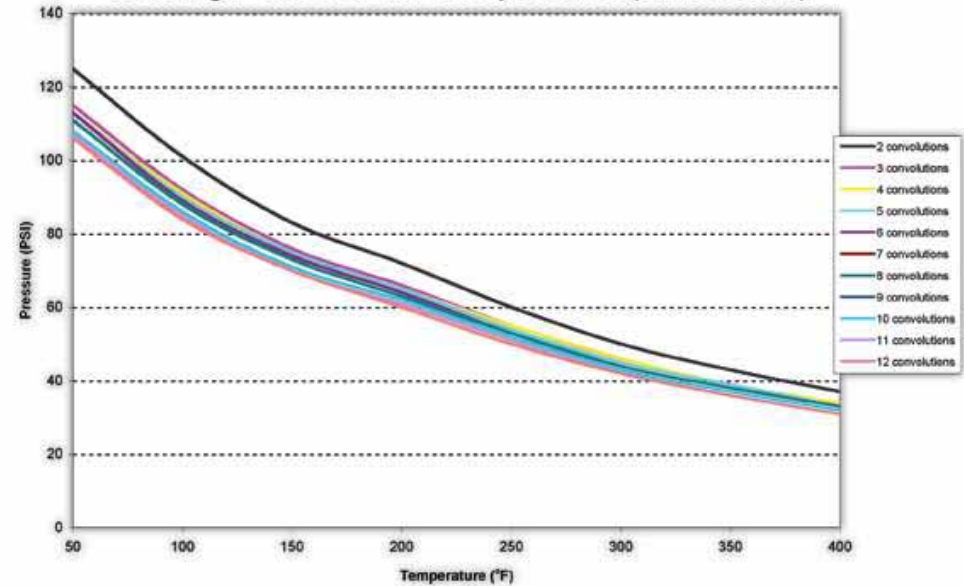

# FLEX30"®



Number of Convolutions	Length (in.)	Axial Movement (+/- in.)	Lateral Movement (+/- in.)	Angular Movement (deg)	Axial Spring Rate (lb./1/8 in.)	Lateral Spring Rate (lb./1/8 in.)	Angular Torque (in.-lb./deg)	Std. Full Vacuum Temp (°F)	Vacubands™ Full Vacuum Temp (°F)	Weight (lbs)
2	5.63	1.06	0.81	4	268	1768	3612	CF	450	400.0
3	7.53	1.63	1.19	6	182	1312	2355	CF	450	429.0
4	9.41	2.16	1.63	8	146	1094	1884	CF	450	458.0
5	11.31	2.69	2.00	10	113	987	1570	CF	450	487.0
6	13.19	3.22	2.44	12	100	892	1256	CF	450	516.0
7	15.06	3.75	2.81	14	89	793	1130	CF	450	545.0
8	16.94	4.28	3.19	15	81	710	1099	CF	450	574.0
9	18.84	4.81	3.69	17	73	643	1005	CF	450	603.0
10	20.75	5.34	4.06	19	66	578	942	CF	450	632.0
11	22.66	5.88	4.50	21	59	527	848	CF	450	661.0
12	24.56	6.44	4.94	23	51	475	754	CF	450	690.0

⚠ Data applicable to LimitLink design only - AntiSquirm design is intended for axial movements only

## LimitLink™ Flexijoint®

Working Pressure vs. Temperature (Non-Shock)

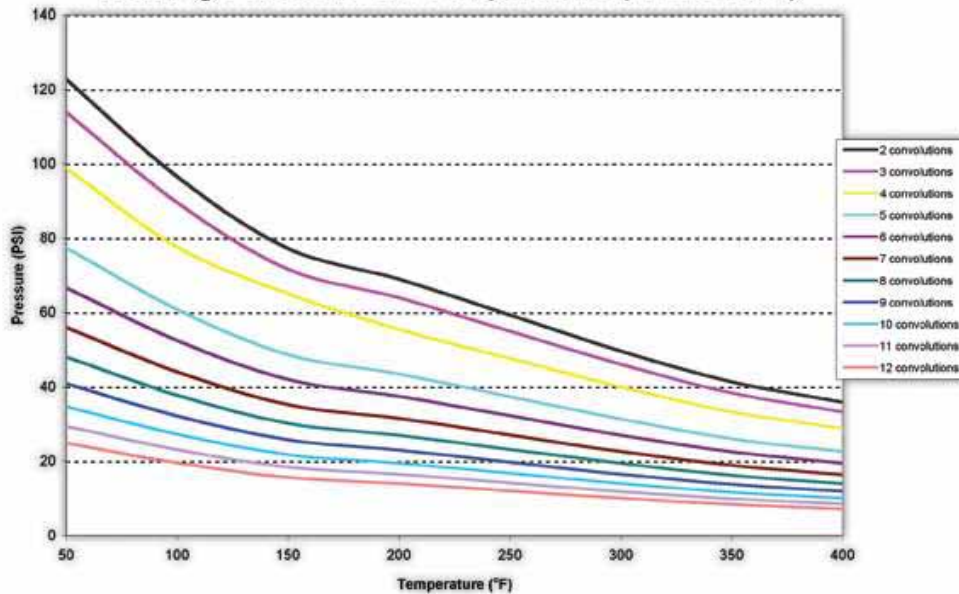

## AntiSquirm™ Flexijoint®

Working Pressure vs. Temperature (Non-Shock)

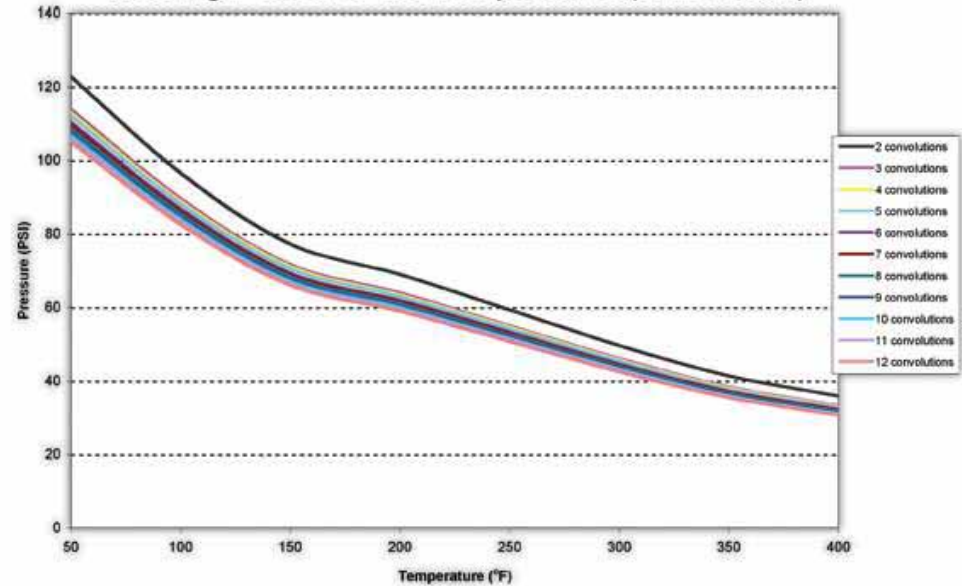

# FLEX32"®



Number of Convolutions	Length (in.)	Axial Movement (+/- in.)	Lateral Movement (+/- in.)	Angular Movement (deg)	Axial Spring Rate (lb./1/8 in.)	Lateral Spring Rate (lb./1/8 in.)	Angular Torque (in.-lb./deg)	Std. Full Vacuum Temp (°F)	Vacubands™ Full Vacuum Temp (°F)	Weight (lbs)
2	5.63	1.06	0.81	4	268	1768	3612	CF	450	475.0
3	7.53	1.63	1.19	6	182	1312	2355	CF	450	504.0
4	9.41	2.16	1.63	8	146	1094	1884	CF	450	533.0
5	11.31	2.69	2.00	10	113	987	1570	CF	450	562.0
6	13.19	3.22	2.44	12	100	892	1256	CF	450	591.0
7	15.06	3.75	2.81	14	89	793	1130	CF	450	620.0
8	16.94	4.28	3.19	15	81	710	1099	CF	450	649.0
9	18.84	4.81	3.69	17	73	643	1005	CF	450	678.0
10	20.75	5.34	4.06	19	66	578	942	CF	450	707.0
11	22.66	5.88	4.50	21	59	527	848	CF	450	736.0
12	24.56	6.44	4.94	23	51	475	754	CF	450	765.0

☀ Data applicable to LimitLink design only - AntiSquirm design is intended for axial movements only

## LimitLink™ Flexijoint®

Working Pressure vs. Temperature (Non-Shock)

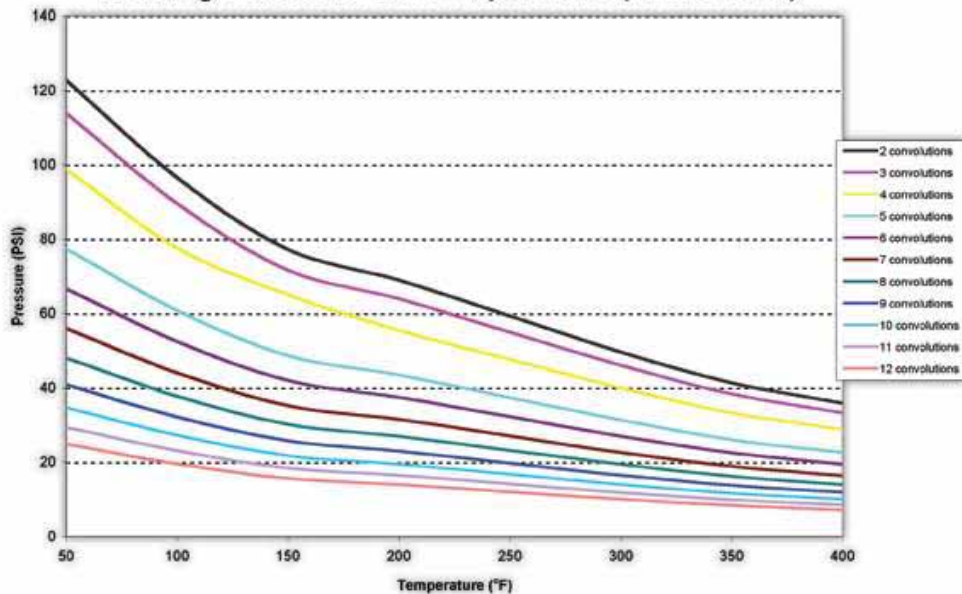

## AntiSquirm™ Flexijoint®

Working Pressure vs. Temperature (Non-Shock)

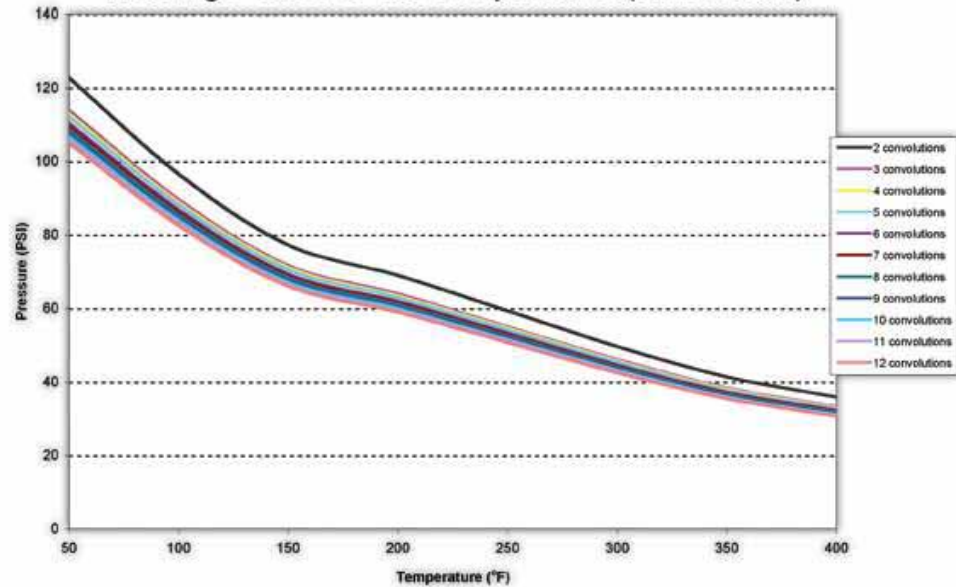

# FLEX36"®



Number of Convolutions	Length (in.)	Axial Movement (+/- in.)	Lateral Movement (+/- in.)	Angular Movement (deg)	Axial Spring Rate (lb./1/8 in.)	Lateral Spring Rate (lb./1/8 in.)	Angular Torque (in.-lb./deg)	Std. Full Vacuum Temp (°F)	Vacubands™ Full Vacuum Temp (°F)	Weight (lbs)
2	6.31	1.25	0.94	4	270	1937	5166	CF	450	650.0
3	8.44	1.84	1.38	6	182	1575	3528	CF	450	692.0
4	10.53	2.41	1.81	8	146	1325	2713	CF	450	734.0
5	12.63	2.84	2.25	10	113	1200	2171	CF	450	776.0
6	14.75	3.63	2.69	12	100	1067	2008	CF	450	818.0
7	16.88	4.25	3.19	14	90	969	1791	CF	450	860.0
8	18.94	4.81	3.56	15	82	875	1601	CF	450	902.0
9	21.06	5.44	4.06	17	74	780	1438	CF	450	944.0
10	23.13	6.19	4.50	19	67	712	1302	CF	450	986.0
11	25.25	6.94	4.94	21	59	650	1172	CF	450	1028.0
12	27.31	7.69	5.38	23	51	587	1043	CF	450	1070.0

☀ Data applicable to LimitLink design only - AntiSquirm design is intended for axial movements only

## LimitLink™ Flexijoint®

Working Pressure vs. Temperature (Non-Shock)

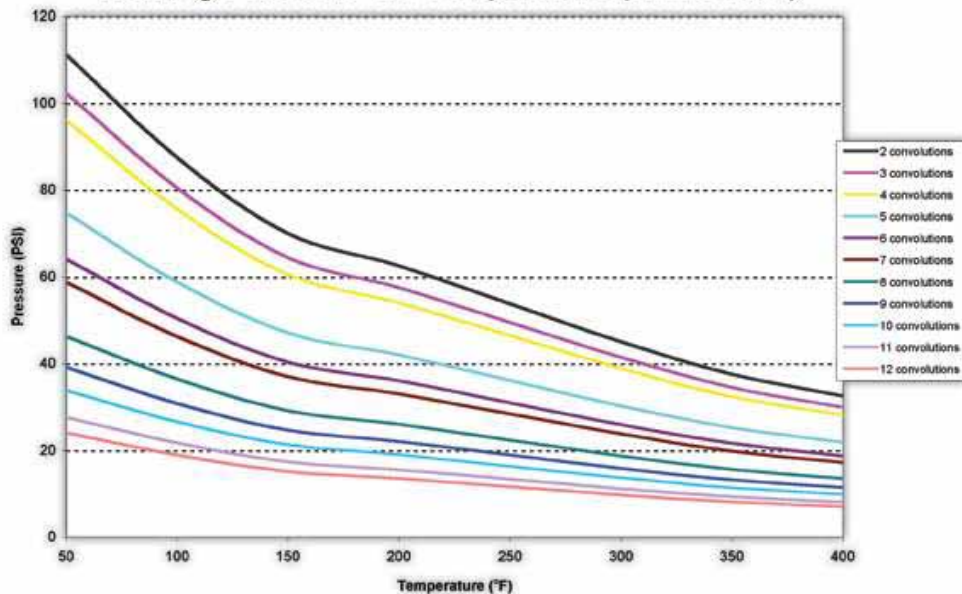

## AntiSquirm™ Flexijoint®

Working Pressure vs. Temperature (Non-Shock)

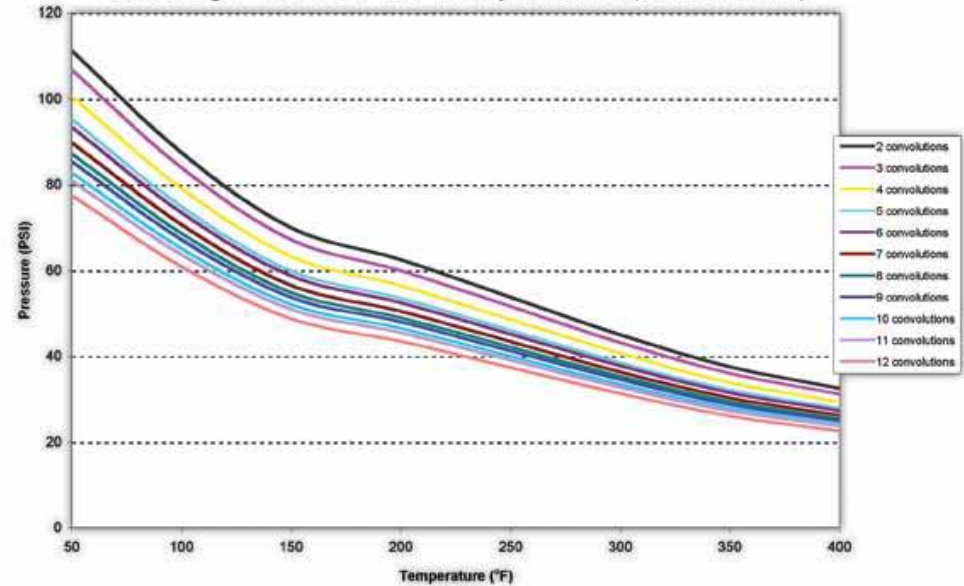

# FLEX42"®



Number of Convolutions	Length (in.)	Axial Movement (+/- in.)	Lateral Movement (+/- in.)	Angular Movement (deg)	Axial Spring Rate (lb./1/8 in.)	Lateral Spring Rate (lb./1/8 in.)	Angular Torque (in.-lb./deg)	Std. Full Vacuum Temp (°F)	Vacubands™ Full Vacuum Temp (°F)	Weight (lbs)
2	7.00	1.38	1.00	2	272	2125	7631	CF	450	910.0
3	9.38	2.00	1.50	4	183	1810	5221	CF	450	974.0
4	11.89	2.69	2.00	6	147	1562	4015	CF	450	1038.0
5	14.00	3.38	2.50	8	114	1425	3214	CF	450	1102.0
6	16.38	4.00	3.00	10	101	1294	2972	CF	450	1166.0
7	18.69	4.69	3.50	12	92	1156	2651	CF	450	1230.0
8	21.06	5.38	4.00	13	83	1043	2369	CF	450	1294.0
9	23.38	6.00	4.56	15	75	937	2128	CF	450	1358.0
10	25.69	6.69	5.00	16	69	844	1927	CF	450	1422.0
11	28.06	7.38	5.50	17	60	768	1734	CF	450	1486.0
12	30.38	8.06	6.00	18	52	700	1544	CF	450	1550.0

☀ Data applicable to LimitLink design only - AntiSquirm design is intended for axial movements only

## LimitLink™ Flexijoint®

Working Pressure vs. Temperature (Non-Shock)

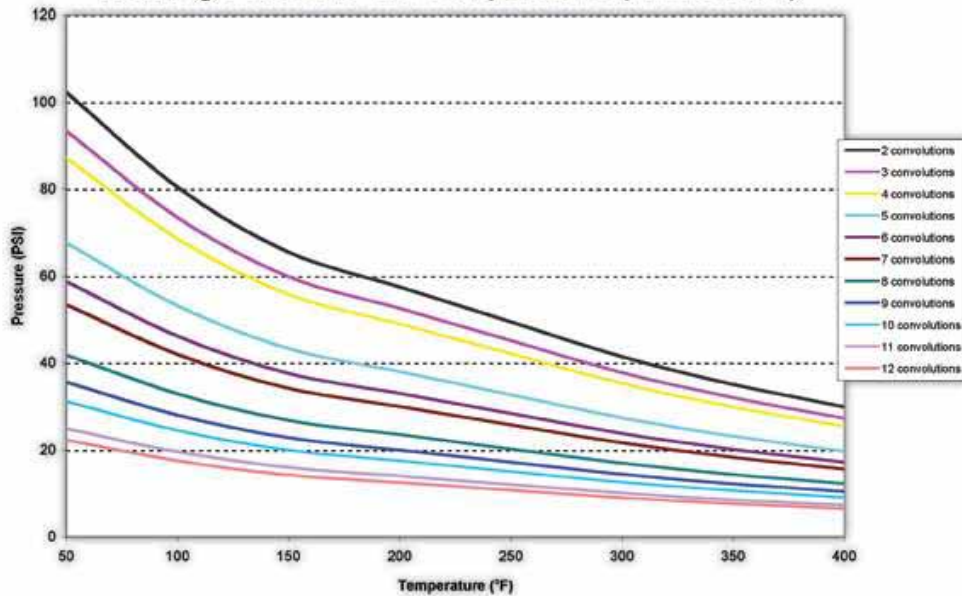

## AntiSquirm™ Flexijoint®

Working Pressure vs. Temperature (Non-Shock)

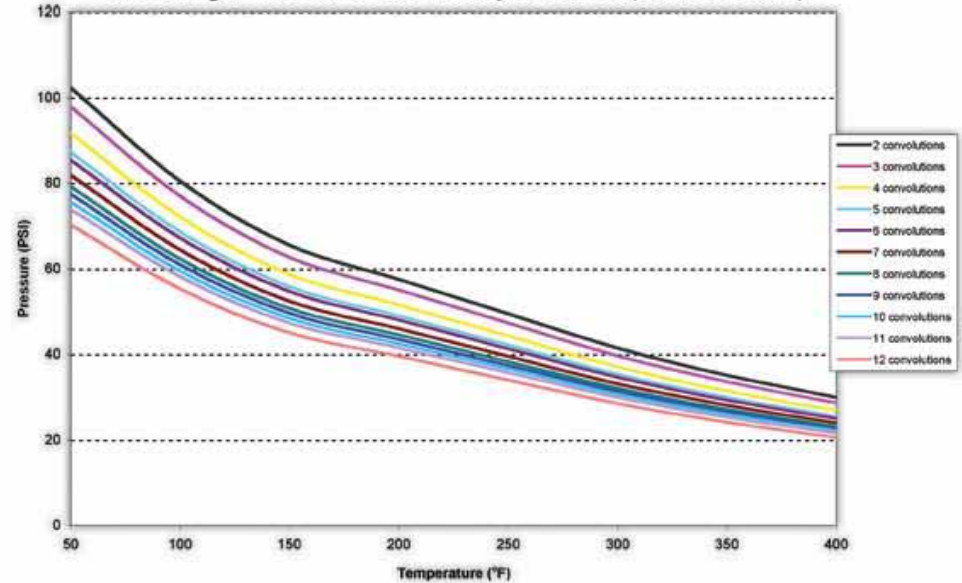

# Flange Dimensions FLEXIJOUNT<sup>®</sup> Technical Data

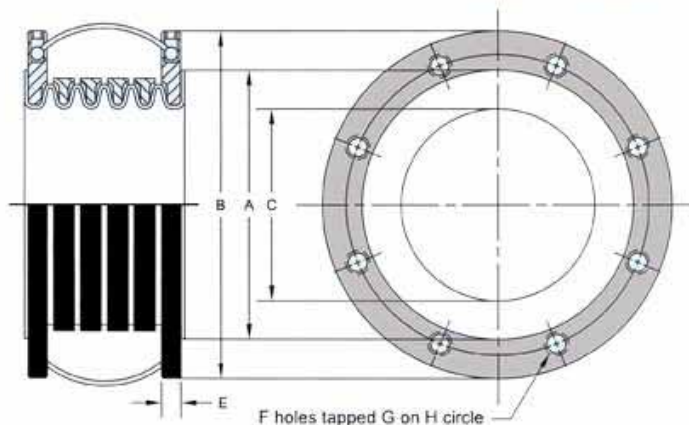

Flexijoint Size	A Flange Face (in.)	B Flange Outside Diameter (in.)	C PTFE Inside Diameter (in.)	E Flange Thickness (in.)	F Number of Holes	G Thread	H Bolt Circle (in.)
1/2	1-3/8	3-1/2	9/16	3/8	4	1/2x13	2-3/8
3/4	1-11/16	3-7/8	13/16	3/8	4	1/2x13	2-3/4
1	2	4-1/4	1	13/32	4	1/2x13	3-1/8
1-1/4	2-1/2	4-5/8	1-3/8	13/32	4	1/2x13	3-1/2
1-1/2	2-7/8	5	1-5/8	7/16	4	1/2x13	3-7/8
2	3-5/8	6	2-1/16	7/16	4	5/8x11	4-3/4
2-1/2	4-1/8	7	2-7/16	5/8	4	5/8x11	5-1/2
3	5	7-1/2	3-1/16	17/32	4	5/8x11	6
4	6-3/16	9	4	9/16	8	5/8x11	7-1/2
5	7-5/16	10	5-1/16	9/16	8	3/4x10	8-1/2
6	8-1/2	11	6-1/16	19/32	8	3/4x10	9-1/2
8	10-5/8	13-1/2	8	11/16	8	3/4x10	11-3/4
10	12-3/4	16	10	11/16	12	7/8x9	14-1/4
12	15	19	11-15/16	5/8	12	7/8x9	17
14	16-1/4	21	13-1/8	13/16	12	1x8	18-3/4
16	18-1/2	23-1/2	15	7/8	16	1x8	21-1/4
18	21	25	16-7/8	15/16	16	1-1/8x7	22-3/4
20	23	27-1/2	18-13/16	1	20	1-1/8x7	25
24	27-1/4	32	22-5/8	1-1/8	20	1-1/4x7	29-1/2
28	31-1/4	36-1/2	26-7/16	1-1/4	28	1-1/4x7	34
30	33-3/4	38-3/4	28-1/4	1-3/8	28	1-1/4x7	36
36	40-1/4	46	34	1-1/2	32	1-1/2x6	42-3/4
42	47	53	41	1-11/16	36	1-1/2x6	49-1/2

While ANSI 150 lb. is standard drilling for Flexijoint flanges, it is possible to supply flanges conforming to many other specifications, such as ANSI 300 lb. bolt circle, Corning glass pipe drilling, DIN, British standards etc. It is also possible to supply Flexijoints with two different size flanges on the same expansion joint. Contact Ethylene for limitations and details.

All materials used in the transfer of fluid (pipe & fittings) expand and contract a known amount per degree of temperature change. This expansion rate typically is expressed as in/in°F. The table below gives thermal coefficient of expansion for some common piping materials.

Pipe Material	Thermal Coefficient of Expansion (in/in°Fx10 <sup>-6</sup> )
Aluminum	13.6
Fiberglass	13.0
Hastelloy C	6.8
Impregnated Graphite	2.4
PTFE lined carbon steel	6.8
PVC 1020	30
300 Series Stainless steel	10.4

The change in pipe length, ΔL, due to temperature change is given by the equation below:

$$\Delta L = \Delta T \times a \times L$$

where: ΔT = change in temperature (°F)

a = thermal coefficient of expansion (in/in°F x 10<sup>-6</sup>)

L = starting length of pipe (in)

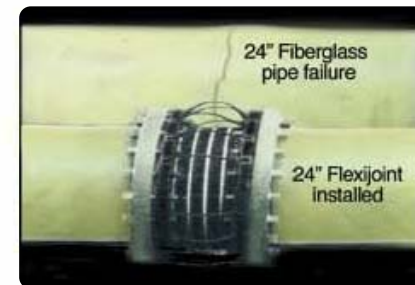
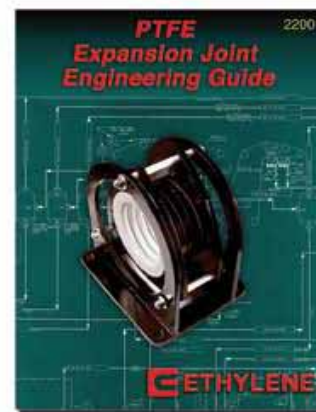

The expansion or contraction of a rigid pipe section that is restrained at both ends will generate a force equal to that required to compress the pipe from its expanded length back to its original length. These forces can be very high and can cause the piping to buckle, compressive failure of the piping or even damage to other equipment.

### Calculation of Force

The force generated by pipe expansion is given by:

$$F = \Delta T \times a \times E \times A$$

where: ΔT = change in temperature (°F)

a = thermal coefficient of expansion (in/in°F x 10<sup>-6</sup>)

E = modulus of elasticity (lbs/in<sup>2</sup>)

A = cross sectional area of pipe (in<sup>2</sup>)

Using Flexijoints will significantly reduce the loads applied to anchors and subsequently the stresses in the piping, eliminating catastrophic failure of piping and all supporting structures and equipment.

Although a complete scope of pipe movement and stress analysis is beyond the capabilities of this brochure, Ethylene has produced a 24 page PTFE Expansion Joint Engineering Guide that is the most comprehensive in the industry. Topics include; materials, anchors, guides & supports, sample installations, bolting considerations, system check list, etc..... Request Ethylene brochure no. 2200

# Typical Installations Common Applications

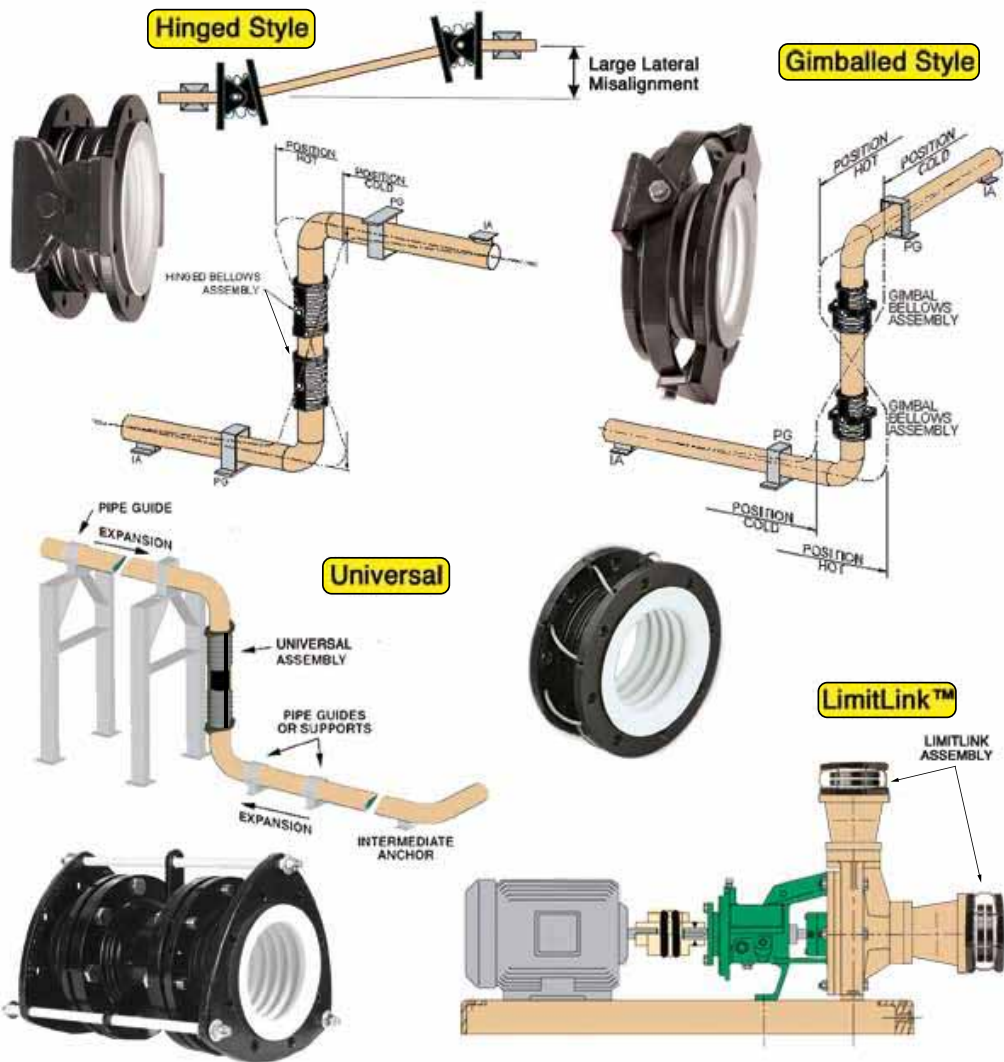

## Piping

All piping used in the transfer of fluid expands and contracts a known amount per degree of temperature change. FRP, glass and other plastic piping are especially stress sensitive at flange connections. FRP piping has a thermal expansion coefficient (10) times greater than carbon steel pipe and it is not uncommon for fiberglass pipe to have more than (2) inches change in length per 100 feet. Flexijoint is the only PTFE expansion joint available with enough axial travel range to handle piping growth with just one expansion joint. Flexijoints can handle more stress than competitors products which allows design engineers the latitude to reduce joint connections and lower project costs.

## Pumps

Flexijoints are excellent vibration control units for pumps and other rotating equipment. They can absorb vibration which is generally transferred to adjoining and adjacent piping thereby eliminating piping leaks and extending pump bearing and seal life.

## HVAC

Flexijoints have high acoustical resistance and have the ability to stop the transmission of noise through HVAC piping and ducts. They are an excellent choice for a lifetime of service in schools, hospitals, airports and any other type of commercial building.

## Weigh Cells

Flexijoints are an excellent choice for weigh tanks. Their low spring rate improves scale accuracy with less calibration requirements.

## Flexijoint Vs. Competition

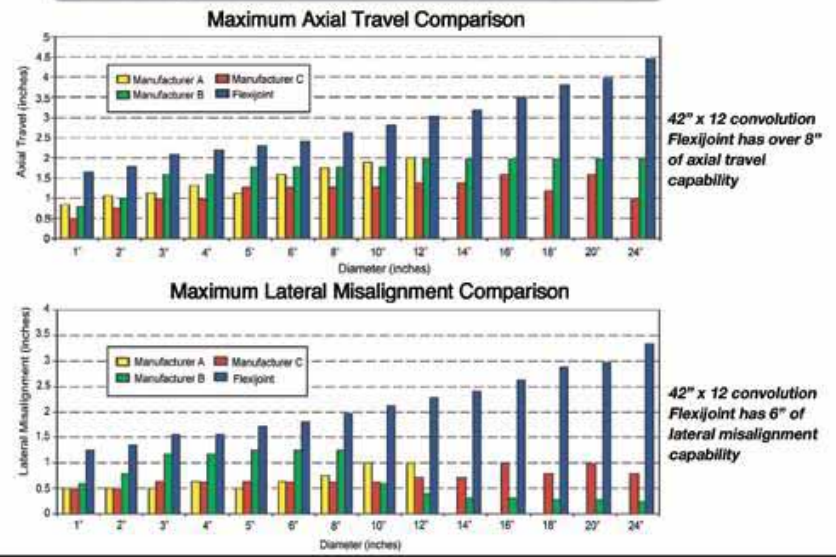



# FLEXIJOINT<sup>®</sup> v.s. Competition



## ISOSTATIC MOLDED TUBING

Ethylene employs only 100% Virgin, high molecular weight PTFE resin in its isostatic tube molding process. No pigments, additives or lubricants whatsoever, just Pure PTFE resin.



## FluoroForming™

All Flexijoints are made by the exclusive Fluoroform™ process, a development of Ethylene. The proprietary technique gently influences the isostatically molded tube to "form" convolutions of uniform thickness and precise geometry. Deep convolutions allow increased axial travel while reducing the force necessary to produce axial movement and lateral misalignment.

Combine all the distinctive features;  
 - 100% Pure PTFE  
 - T-Band™ root and sidewall support  
 - T-Band™ protection from over-compression  
 - LimitLink™ protection from over-expansion with the Fluoroform™ process, and the relationship of these features provide the basis for the outstanding performance of Flexijoints.

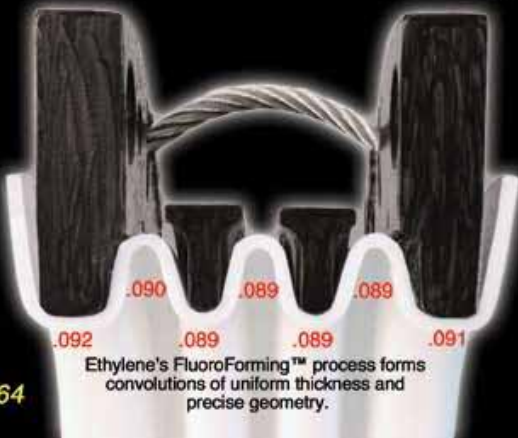

Ethylene's FluoroForming™ process forms convolutions of uniform thickness and precise geometry.

**High Performing  
Severe Service  
Longest Flex-Life**

1

*It all starts with the resin...*

2

*The process...*

3

*The End Result...*

## PASTE EXTRUDED TUBING

In the "Paste Extruding" process, hydrocarbon based solvents additives must be added to PTFE as a lubricant in order to facilitate the extrusion process. These solvents are not only hazardous but could also contaminate contacting fluids by leaching out or could be vulnerable to blistering. Paste extruded expansion joints are NOT Pure PTFE.



## Blow Molding (Contour Molding)

"Blow Molding", sometimes referred to as "Contour" molding by some manufacturers is a very economical means of manufacturing expansion joints. The process, during which a plastic parison (hollow tube) is heated above the transition temperature and is placed between two halves of a mold (cavity) and forced to stretch to assume the shape of that mold cavity by the use of air pressure. Wall thickness distribution is severely impacted as shown in the expansion joint cross-section on right and below.

Contour Molding (Blow Molding) is an excellent low cost technique for products such as plastic milk jugs or soda bottles where yielding of the plastic is not a potential liability....



Severe thinning is evident by the translucency of the convolutions above. Permanently yielding (stretching) PTFE beyond its elastic limit will compromise the materials mechanical integrity and can cause sudden premature failure.



**Economical  
Light-Duty Service  
Limited Flex-Life**



Blow Molding (Contour Molding) severely impacts wall thickness uniformity and geometry as shown below



# Application Data Sheet **FLEXIJOINT**<sup>®</sup> How to Order & Specify

Please copy or scan this sheet to request pricing and delivery and fax or email to Ethylene or an authorized Ethylene distributor. You can also use the data sheet online at [www.ethylene.com](http://www.ethylene.com)

Company name \_\_\_\_\_ Location \_\_\_\_\_

Contact \_\_\_\_\_ Phone \_\_\_\_\_

Is bellows replacing an existing unit or another manufacturer? No  Yes

If yes: Manufacturer \_\_\_\_\_ Part Number or Style \_\_\_\_\_

### Design Requirements

Description of application (Type of equipment, piping and fluid system)

Diameter if known \_\_\_\_\_ (in) Number of Convolutions \_\_\_\_\_ Neutral Length \_\_\_\_\_ (in)

If unknown, specify desired flow rate \_\_\_\_\_ (gpm)

### Movement Requirements

Axial \_\_\_\_\_ (in) Lateral \_\_\_\_\_ (in) Angular \_\_\_\_\_ (deg)

Fluid \_\_\_\_\_

Temperature normal operating \_\_\_\_\_ °F, Maximum \_\_\_\_\_ °F, Minimum \_\_\_\_\_ °F

Pressure Maximum \_\_\_\_\_ (psig) Vacuum? No  Yes  \_\_\_\_\_ In Hg

Pressure Cycles \_\_\_\_\_ Max (psig) \_\_\_\_\_ Min (psig) \_\_\_\_\_ Frequency \_\_\_\_\_

Pressure Surges (explain) \_\_\_\_\_

### Additional Information

Number of units \_\_\_\_\_

Slurry or Solids present? No  Yes

Is steam present? No  Yes  \_\_\_\_\_ (psig) \_\_\_\_\_ °F Is static charge a concern? No  Yes

Atmosphere Corrosive No  Yes

Is flexing involved? No  Yes  Amplitude of motion \_\_\_\_\_ Cycles per hour \_\_\_\_\_

Special considerations (please explain)

Example Describes: 6" Flexijoint with Ductile Flanges, LimitLinks, No LinerSleeve, 150 lb Flange Drilling, 3 convolutions and No Specials

6 D I B A 3 S O

### Size

Figure Shows Nominal Pipe Size (in.) 1/2" to 42"

### Flange material

D = Ductile Iron  
C = Carbon Steel  
F = Durcor-62™ Composite  
S = Stainless Steel

### Axial Restraint

I = LimitLinks  
Q = LimitBolts  
U = AntiSquirm

### # of Specials

# of Convolutions 2 to 12

### Flange Drilling

A = ANSI 150 lbs. (Std)  
O = Glass Flange  
E = Clearance Holes  
S = Other

### LinerSleeves

B = No LinerSleeve  
P = PTFE Liner  
S = Stainless Steel

### 1.0 SCOPE

- 1.1 This specification provides information for the procurement of expansion joint, flexible couplings and bellows made of PTFE Fluorocarbon resin by forming.
- 1.2 The subjects covered are material, construction, tests and packaging.
- 1.3 Safety - always specify safety shields to protect against serious personal injury in the event of expansion joint failure.

### 2.0 MATERIALS

- 2.1 The bellows component shall be pure white virgin PTFE resin conforming to ASTM D 1457 without pigments, lubricants, hydrocarbons or additives of any kind.
- 2.2 Unless otherwise specified, the flange alloy and reinforcing rings shall conform to ASTM 60-45-12. Composite flanges and reinforcing rings shall have a nominal tensile strength of 50,000 psi per ASTM D-638 or 358 Mpa and ASTM-D256 or 1760 J/M for notched Izod impact strength of 30 ft. lb/inch.
- 2.3 Unless otherwise specified, all flanges and T-Bands shall be coated with an electrostatically applied epoxy.
- 2.4 Unless otherwise specified, all materials subject to atmospheric corrosion shall be zinc phosphate treated or PureFlex Durcor-62™ advanced composites.

### 3.0 CONSTRUCTION

- 3.1 Unless otherwise specified, flange diameter shall conform to ANSI B16.5. Bolt holes shall be tapped.
- 3.2 When external band reinforcement is required each reinforcing element shall be one piece without welding or pins and shall reinforce the full length of the convolution sidewall as well as the convolution root.
- 3.3 The PTFE wall thickness shall be no less than .077". It shall be uniform within 5% of the nominal wall thickness measured at any point on the convolution sidewall, crest, or root.
- 3.4 When mechanical limiting to a maximum extended length or to a minimum retracted length is required, the means by which such limiting is accomplished shall not interfere with freedom to adjust to angular, parallel, or rotary misalignment.

### 4.0 TESTING

- 4.1 No leakage shall occur after 100,000 minimum cycles (200,000 strokes) of the maximum rated axial travel, 10 cycles per minute, at room temperature.
- 4.2 Each expansion joint shall be subjected to a minimum pressure test of 100 psi.
- 4.3 The PTFE component shall have a minimum ultimate tensile strength of 4,000 psi and a minimum ultimate elongation of 300% by ASTM D1708 and a minimum specific gravity of 2.14 by ASTM D792.
- 4.4 The PTFE components shall be free of scratches, tool marks, dents, pits, tears, inclusions or any other defects which occupy or penetrate 20% or more of the PTFE wall thickness.
- 4.5 All units will be subjected to a high intensity light to test for imperfections and inclusions.
- 4.6 The entire surface of each finished unit shall withstand a 10,000 volt spark test without arcing through.

### 5.0 PACKAGING

- 5.1 Each unit shall be packed in a separate container, clearly marked externally to show the pipe size, the number of convolutions and the manufacturer.
- 5.2 All containers shall be readily reclosable with retaping.
- 5.3 Each unit shall bear a nameplate or other marking to show pipe size and the manufacturer.
- 5.4 An instruction sheet showing recommended installation procedure, bolt tightening torque, maximum extended length, neutral length, and minimum retracted length shall be enclosed in each expansion joint container.

### 6.0 HAZARDOUS SERVICE WARNING LABEL

- 6.1 Each unit shall be shipped with a minimum of one warning label stressing the absolute urgency of using a suitable safety shield in hazardous service and using a liner in abrasive service or where sharp edged solids are or may be present.

**WARNING**

Safety Shields must be used at all times in hazardous service to protect against serious personal injury in the unlikely event of expansion joint failure. LinerSleeves should always be used in abrasive service or where sharp-edged solids are or may be present.

**T-Line Strainers™**  
Fully Lined ETFE or PFA  
Strainer



**EthylArmor®**  
PTFE lined & Covered  
Dip Pipes & Spargers



**pHampler®**  
Reactor sampling,  
Monitoring & Control  
System



**MonoDerm™**  
Large Diameter Lined  
Pipe and Special Shapes

**DURCOR-62**  
TOUGH

**FLO-VU®**  
Sight Indicators  
With Safety Shield  
FACTORY MUTUAL APPROVED



**Flexijoint®**  
With Durcor-62™  
Advanced Composite Flanges



**ETHYLENE LLC**

755 Central Ave. - Murray Hill, NJ 07974

Ph (908)464-2600 FAX (908)464-8694

www.ethylene.com

ETHYLENE LLC. INFORMATION IS BASED ON TECHNICAL DATA AND TESTING THAT ETHYLENE BELIEVES TO BE RELIABLE AND IS SUBJECT TO CHANGE WITHOUT NOTICE. THE INFORMATION IS INTENDED FOR USE BY PERSONS HAVING TECHNICAL SKILL, AT THEIR OWN DISCRETION AND RISK. SINCE CONDITIONS AND USE OF PRODUCTS ARE OUTSIDE OF ETHYLENE'S CONTROL, ETHYLENE LLC. MAKES NO WARRANTIES, EXPRESS OR IMPLIED AND ASSUMES NO LIABILITY IN CONNECTION WITH ANY USE OF THIS INFORMATION. DURCOR-62™ IS A TRADEMARK OF PUREFLEX, INC. ETHYLENE™, FLEXIJOINT®, FLEXARMOR®, FLO-VU®, ETHYLARMOR®, PHAMPLER®, MONODERM™, T-LINE STRAINERS™, T-BANDS™ AND LIMITLINKS™ ARE EITHER REGISTERED OR TRADEMARKS OF ETHYLENE LLC.

FLEXIJOINT 12-06